

## ATL-450 LOW PROFILE AUTOMATIC VEHICLE RESTRAINT



### FEATURE SUMMARY

- Non-Impact Design
- Barrier Stores 9" High to Escape Impact From Low Rear Impact Guards
- Barrier Sensor Communicates Positive Lock Position
- HYDRA-FLOAT™ Barrier Automatically Adjusts to Truck Movement During Loading
- Vertical Locking Hook Secures Virtually All Rear Impact Guards With In Excess of 32,000 lbs. of Restraining Force
- NEMA 12 Panel Enclosure
- Self Cleaning Guide Track
- Vertical Operating Range From 9" to 30"
- Easy to Install & Simple to Operate
- Inside and Outside Communication Lights and Signs
- 5 Year Structural Warranty
- Virtually No Required Maintenance
- Housing Encloses Working Parts From Inclement Weather and Debris
- All Weather Zinc Plated Components for Superior Durability
- Mounting Force in Excess of 100,000 lbs.

*Dedicated People ~ Superior Products*



## SPECIFICATIONS

### VEHICLE RESTRAINT SYSTEM

#### DESCRIPTION

The TRUCK-LOCK® Series vehicle restraints improve safety with strength, convenience and reliability.

The ATL-450 Model is a premium automatic unit designed to secure a truck at the loading dock by engaging the rear impact guard with a large barrier.

The housing/barrier combination is stored down and clear of incoming trucks while protecting working parts from weather and debris.

The barrier mounted sensor provides positive communication that the rear impact guard is engaged.

The HYDRA-FLOAT™ barrier automatically adjusts to various heights of trucks and maintains position during loading. The operator easily activates and stores the barrier with a push of a button.

The low profile barrier stores at only 9" high and raises to 30" to restrain all types of rear impact guards.

#### OPERATION

The trailer is backed into position at the loading dock until contacting the dock bumpers. The driver sets the brakes and chocks the wheels. The dock attendant pushes a control button that activates the barrier that will rise in the vertical track until contacting the rear impact guard and securing the trailer to the loading dock.

An override selector button will allow a bypass operation of the dock leveler while maintaining a red external signal light.

The barrier provides a restraining force in excess of 32,000 lbs. adjusting automatically to "trailer float" during loading and unloading ensuring the trailer is restrained at all times.

When loading/unloading is completed the dock attendant stores the barrier using the release button.

#### COMMUNICATION

Safety equipment includes flashing red or green inside and outside lights, operator instructions and outside mounted sign with forward and reverse lettering for truck driver.

#### WARRANTY

One-Year parts and labor & Five-Year structural warranty from date of shipment. Warranties are subject to limitations on liability.

#### CONSTRUCTION

Enclosed barrier and housing design is a structural welded assembly constructed with dual reinforced 1/2" steel restraining arms and 1/4" steel enclosure panel. The housing protects components from the affects of weather, dirt and debris. Dual 1/2" steel reinforced vertical track is welded securely to a 3/8" thick wall mounting plate.

All structural components including the mounting plate, track, barrier, and lift arms are zinc plated for high corrosion resistance.

The control panel includes a power unit and control system in a NEMA 12 enclosure with push buttons, operating instructions and communication lights on the cover.

Black and yellow warning labels are provided on moving barrier.

Power requirement is 120VAC, 3 amps.

#### INSTALLATION

All Nordock TRUCK-LOCK® Model ATL-450 vehicle restraints are factory assembled and tested.

The restraint is mounted to the dock face by means of concrete wedge anchors and welding to the pit curb angle.

An alternate method is to weld the restraint to a dock face embedded steel plate. Total mounting force is in excess of 100,000 lbs.

Signs, control panel and optional components are installed in accordance to instructions contained in the installation and owners manual.

#### DIMENSIONS

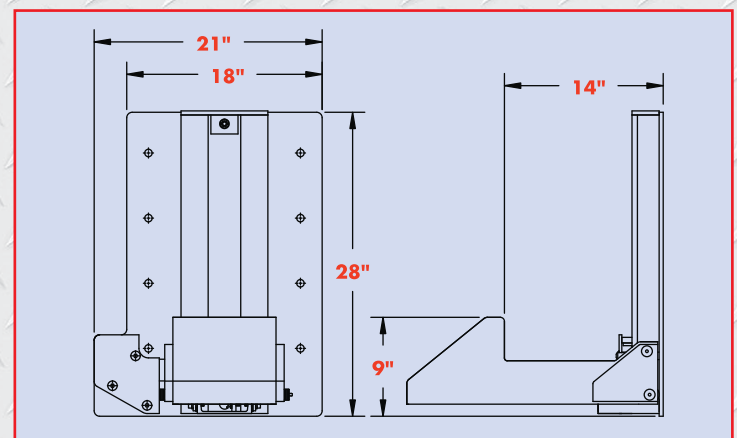

#### OPTIONS & ACCESSORIES

- Cantilever Extension Mounting Bracket
- Cast-In Wall Mounting Plate
- LED Lights
- Integrated Control Systems
- Keyed Override Switch

# NORDOCK® INC.

Website: [www.nordockinc.com](http://www.nordockinc.com) ~ Email: [Sales@nordockinc.com](mailto:Sales@nordockinc.com) ~ Toll Free: 866-885-4276

Nordock Inc. reserves the right to make changes to specifications without notice or obligation. Nordock products are covered by various U.S. and foreign patents or pending applications.