



AN INTEGRATED WAREHOUSE SOLUTIONS BRAND

405 LAKE ROAD, UNIT 2  
 BOWMANVILLE, ON L1C 4P8  
 T: 905-697-4276 F: 905-697-6422  
 www.nordockinc.com

**VERTICAL DOCK LEVELER TRANSMITTAL**

**2023**

DATE:	EMAIL:
SALES PERSON:	QUOTED BY:
PHONE:	FAX:

BILL TO:	SHIP TO: SAME AS BILLING ADDRESS	END USER:
----------	----------------------------------	-----------

P.O. #:	REQUEST SHIP DATE:	SHIP VIA:	WEIGHT	PPD	COL	3RD
---------	--------------------	-----------	--------	-----	-----	-----

NV MODEL: _____ QUANTITY: _____		NVTL MODEL: _____ QUANTITY: _____		LIST PRICE
<b>STANDARD FEATURES:</b>	NEMA 12 CONTROL DOCK STORED SWITCH REMOTE POWER UNIT 20" LAMINATED BUMPER & RISERS	NEMA 12 CONTROL DOCK STORED SWITCH REMOTE POWER UNIT 20" LAMINATED BUMPER & RISERS BUMPER-TO-BUMPER™ PIT SEAL		
<b>DOCK LEVELER SIZE:</b>	6X6 6X8 6.5X6 6.5X8 7X6 7X8 OTHER: _____	7X6 7X8 OTHER: _____		
<b>CAPACITY:</b>	25K 30K 35K 40K 45K 50K 60K OTHER: _____	30K 40K 50K OTHER: _____		
<b>FRAME DEPTH:</b>	12" 15" SPECIAL: _____	12" 15" SPECIAL: _____		
<b>LIP LENGTH: *Standard</b>	16"* 18" 20" OTHER: _____	20"* OTHER: _____		
<b>OPTIONS:</b>	FOAM FILLED PIT SEAL NEMA 4 CONTROL REAR CAST IN ANGLE REDUCED LIP BEND PANEL AND POWER UNIT MOUNTING STANCHION SPRAY ZINC FINISH AND STAINLESS STEEL HINGE ROD	NEMA 4 CONTROL REAR CAST IN ANGLE REDUCED LIP BEND FLOOR MOUNTED TRAILER PANEL AND POWER UNIT MOUNTING STANCHION SPRAY ZINC FINISH AND STAINLESS STEEL HINGE ROD		
<b>VOLTAGE:</b>	SINGLE PHASE THREE PHASE 120V 208V	240V 480V 600V OTHER: _____		
<b>BUMPERS (2/DOCK): *Standard</b>	FF-420-8 LAMINATED* FFS-520-8 STEEL FACE NONE RISER: _____"	SB-823 STEEL SPRING OTHER: _____ EXTENSION: _____"		
<b>CURB ANGLE(S):</b>	FRONT 4X4L REAR 5X5L SIDE/DOOR 3X3L (SEE ILLUSTRATION BELOW)			
<b>DOCK LIGHT:</b>	MODEL: _____			
<b>EXISTING VEHICLE RESTRAINT:</b>	YES NO DISTANCE FROM GRADE TO TOP OF BACKPLATE: _____			

SPECIAL REQUIREMENTS:	LIST PRICE
	SPECIAL REQUIREMENTS
	TOTAL LIST EACH
	DISCOUNT (%)
	<b>TOTAL</b>

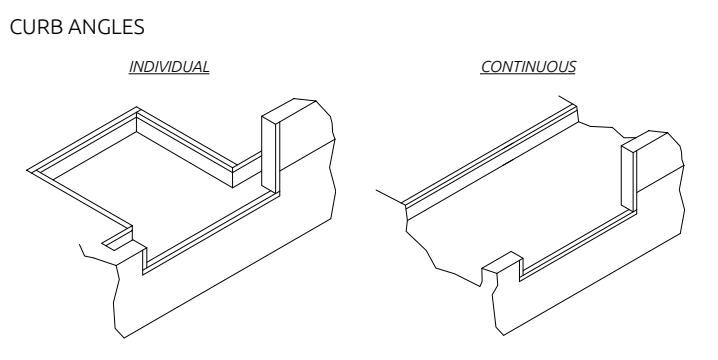

APPLICATION SURVEY	
DOCK HEIGHT:	APPROACH GRADE:
HIGHEST TRUCK BED:	LOWEST TRUCK BED:
HEAVIEST GROSS LOAD:	TRUCKS PER DAY:
3-WHEEL LIFT TRUCKS:	YES NO

TOTAL DISCOUNT	
TOTAL NET EACH	
X QUANTITY	
<b>SUB-TOTAL</b>	
FREIGHT	
TAX AMOUNT (\$)	
<b>TOTAL</b>	