

# NORDDOCK BOXCAR SERIES HYDRAULIC RAIL DOCK

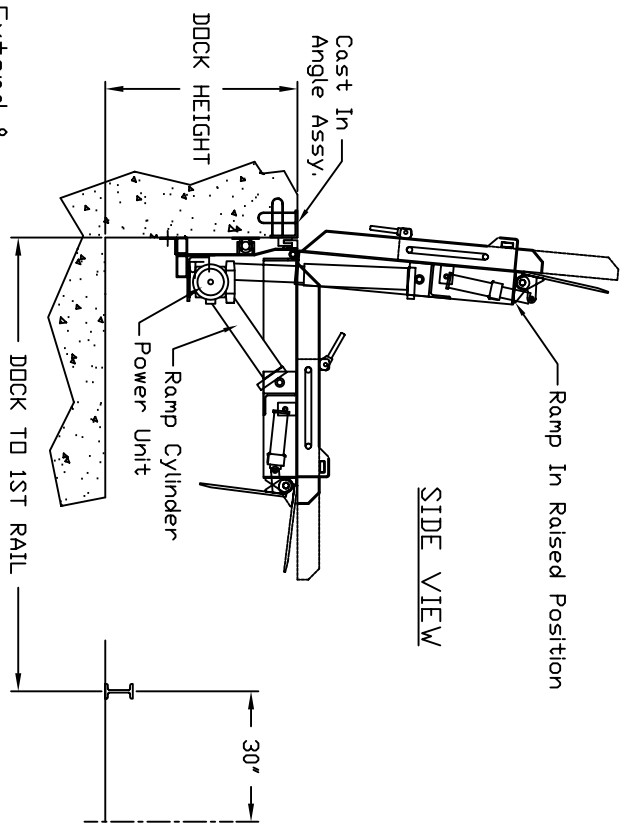
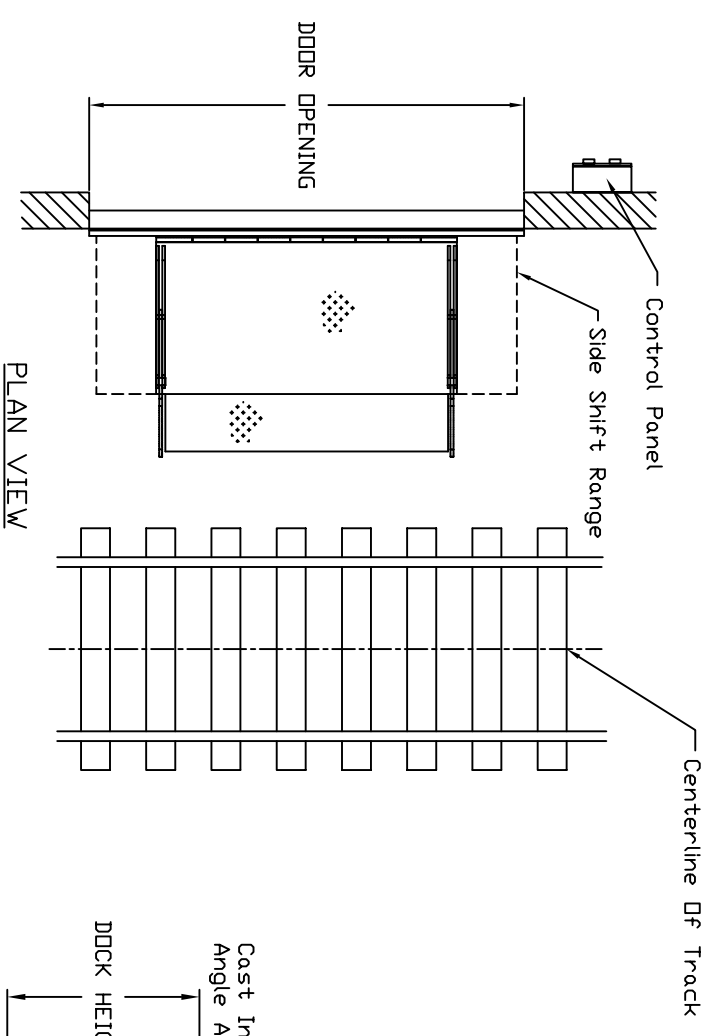

**Feature Summary:**

Fully Hydraulic Push Button Operation Including Lift, Lip Extend & Side Shift. Hydraulic Side Shift Cylinder Locks Deck From Shifting During Loading Operation. Support Arms Adjust For End Loading and Lock In Position. Mechanical Latch to Hold Deck In Upright Stored Position. Continuous Support Rail For Maximum Deck Strength and Curb Attachment. Side Deck Curbs Constructed of Solid Steel 4" High.

**Construction:**

Deck Plate, Lip Plate, Beam Sections & Lugs are of Minimum 50KSI Material. Power Unit Includes A 1 HP TENN Motor Prewired and Fully Plumbed & Tested. Control Panel is NEMA 12 Wall Mounted With 120 Volt Secondary Voltage. Hydraulic Cylinders are Heavy Duty Regenerative Type With Polished Chrome Rods, Guide, Bearings and High Pressure Seals. Hoses are SAE 100R2 High Pressure. Front & Rear Hinge Rods are SAE 1045 Zinc Plated & Coated With Anti-Seize Lubricant.

**MODEL NR ORDER INFORMATION**

RAMP WIDTH \_\_\_\_\_ CAPACITY \_\_\_\_\_ LBS.  
 QUANTITY \_\_\_\_\_ ORDER DATE \_\_\_\_\_  
 DOCK TO CENTERLINE OF FIRST RAIL\* \_\_\_\_\_  
 DOOR OPENING WIDTH \_\_\_\_\_ DOCK HEIGHT \_\_\_\_\_  
 TRAIN CAR HEIGHT RANGE \_\_\_\_\_  
 CURVED TRACK YES  NO  (IF YES, A SITE PLAN IS REQUIRED)  
 VOLTAGE SUPPLY 208  230  460  600   
 BILL TO: \_\_\_\_\_  
 SHIP TO: \_\_\_\_\_  
 \* IF LESS THAN 80° SIGNED CUSTOMER APPROVAL IS REQUIRED.  
 NAME & POSITION \_\_\_\_\_