

**Hydraulic Dock Leveler**  
**Barrier Series**  
**Model "NB"**  
**60,000 to 80,000 lbs. Capacity**

**Operation and Maintenance Manual**

This manual applies to dock levelers manufactured on or after  
February 2017, with Serial Numbers 37900 and greater.

**P/N: 49-0179-B**

*NORDOCK INC.*

Website: [nordockinc.com](http://nordockinc.com) ~ Email: [sales@nordockinc.com](mailto:sales@nordockinc.com) ~ Toll free: 866-885-4276  
Nordock Inc. reserves the right to make changes to specifications without notice or obligation. Nordock products may be covered by  
various U.S. and foreign patents or pending applications.

# Table of Contents

Table of Contents .....	1
Preface .....	2
Problems, Errors and Omissions .....	2
Dock Identification .....	2
Copyright .....	2
Warranty .....	3
Safety .....	4
Maintenance Procedure.....	5
Labels.....	6
Installation .....	7
Pit Check .....	7
Dock Installation .....	7
Bumper Install.....	12
Operation .....	13
Standard (Single Pushbutton) Control Panel .....	13
Below Dock Control .....	13
Optional (Lip Extend and/or On/Off Switch) Control Panel .....	13
Below Dock Control .....	14
Auto Return .....	14
Maintenance and Lubrication .....	15
Acceptable Lubricants and Oils .....	16
Hydraulic.....	16
Grease.....	16
Light Oil.....	16
Hydraulic Adjustment.....	16
Parts and Service Tables .....	17
Section 1 – Deck and Lip Assembly .....	18
Section 2(a) – 60K Frames.....	19
Section 2(b) – 80-100K Frames.....	20
Section 3 – Power Pack and Related Hydraulic Components .....	21
Section 4 – Hydraulic Cylinders.....	22
Section 5 – Hydraulic Lines and Fittings.....	22
Section 6 – Optional Equipment .....	24
Section 7 – Control Panels .....	24
Wiring Diagrams .....	25

# Preface

## **PLEASE READ AND UNDERSTAND THIS MANUAL COMPLETELY**

This manual gives detailed information and instruction on how to operate and maintain your equipment correctly. Failure to do so could result in personal injury, and/or equipment damage. Please consider this manual a permanent part of the unit and keep it with the dock leveler for reference whenever needed.

If you have any questions about this manual, the dock leveler, it's components, or our products and services, please call us at 1-866-885-4276 and we will be happy to assist you. With proper care and maintenance, this dock leveler is designed to work effectively and efficiently for many years to come.

### Problems, Errors and Omissions

This manual has been prepared with the utmost care and attention to detail as to ensure accurate parts and service information should the need arise. Nordock Incorporated believes this manual will provide the operators of this unit all the necessary information required to operate and maintain it for many years. If you believe there is an error, if you have a problem following the guidelines, or if there is information that you feel is missing from this manual, please contact us at the above number so we may attend to the issue immediately.

### Dock Identification

It is very important that in order to provide the best possible service from Nordock Inc., please include the model, serial number and capacity of the dock leveler whenever you contact us. Below is the same serial number decal that will be found on the left side frame rail (standing on the dock, facing the lip). Please fill in the information from the decal on the dock leveler to this area. This will greatly reduce the possibility of improper parts being shipped to you.

<b>NORDOCK®</b>	
<b>DESCRIPTION</b>	
XX XX XX000 LBS	
<b>SERIAL #:</b>	XXXX
866-885-4276 ~ WWW.NORDOCKINC.COM	
MADE IN CANADA	

### Copyright

This manual is copyright to Nordock Incorporated. All information, text, drawings, and technical data contained herein are for reference only. No part of this manual may be copied, altered, or stored on electronic media, and cannot be revealed to others for the purpose of competition.

## Warranty

Nordock Inc. expressly warrants that it's Model NB, BARRIER™ Series hydraulic dock leveler shall remain free of defects in material and workmanship under normal use for a period of one-year from the date of delivery to the purchaser. The purchaser must maintain and operate the product in accordance with proper procedures. In the event the product proves defective in material or workmanship, Nordock Inc. will either:

1. Replace the product or the defective portion thereof without charge to the purchaser; or,
2. Alter or repair the product on site or elsewhere, as may deem advisable, without charge to the purchaser.

In addition, Nordock guarantees, under specified guidelines, the structural components\* for Ten-Years, the front and rear hinges for Twenty-Years and the hydraulic components\* for Five-Years. All structural guarantees are based on the Nordock Application Guide and must be adhered to.

The warranty stated herein is that offered by Nordock Inc. and expressly disclaims all implied warranties including those of merchantability and fitness. This warranty does not cover any failure caused by improper installation, misapplication, overloading, abuse, negligence, or failure to maintain and protect the equipment from vehicle impact. Nordock Inc. or its representative assume no responsibility or liability for any incidental or consequential damages of any kind including loss of use of any equipment, damage or failure resulting from the use of unauthorized replacement parts or equipment modification, or damages resulting from the misuse of the equipment.

Nordock Inc. warranties extend only to the product itself. Nordock Inc. disclaims all liability of any kind arising out of the workmanship, methods and materials used by the installer or premature product wear, product failure, property damage or bodily injury arising from improper installation.

These warranties as stated herein are the exclusive remedies for all claims.

\* Structural components include the deck, lip and frame welded assemblies. Hydraulic components include the motor, pump, hydraulic cylinders, hose and fittings.



## Safety



### **WARNING**

**The operators of this unit must read these safety practices before installing, operating or servicing the dock leveler. Failure to follow these safety practices may result in bodily injury, property damage or death.**

Read and follow the operating instructions contained in this manual before operating the dock leveler. If you do not understand the instructions, contact your supervisor for explanation and instruction on the safe operation of this unit. The following guidelines are to be used in conjunction with all laws, governances and codes in effect where the dock leveler is installed.

1. Inspect the dock leveler both before the truck arrives, and once it has left to ensure that all parts are undamaged and in good working order. If the dock leveler does not appear to function properly, or if it looks damaged, disconnect the power supply, lock out the control panel and report it immediately to your supervisor and safety representative.
2. Be sure that the tires of the truck are properly chocked, or that the truck is properly locked in place by a functioning restraining device before loading or unloading.
3. Stay clear of the dock leveler when it is in motion.
4. Do not operate the dock leveler with equipment, material, or people on the ramp or lip. **Never use a fork truck or any type of material handling equipment to lower the ramp.**
5. Keep hands and feet clear of hinges at all times. Do not attempt to raise the ramp or lip manually. If the dock leveler fails to operate using the procedures contained in this manual, do not use the dock leveler. Disconnect the power supply, lock out the control panel and report it immediately to your supervisor and safety representative. Contact Nordock Inc. or an authorized service representative for service.
6. Use extreme caution when installing the maintenance/support stand. Stay clear of the dock until it has risen fully. **Do not stand under the dock after the stand has been removed.** The lip may fold rapidly, striking the worker.
7. Be sure both lip and deck maintenance support stands are in place, the power has been disconnected and the control panel locked out before entering the dock leveler pit area. See also Maintenance Procedure next page.
8. Any work to be performed on the electrical system must be carried out by a qualified electrician.
9. Any work to be performed on the hydraulic system must be carried out by a qualified hydraulic technician or specialist.

10. Ensure the dock leveler is clear of all material, equipment, or people before the chocks are removed, or the truck is released from the restraint. After loading or unloading, make sure the dock has been returned to its level, stored position.

If you have any questions, contact your supervisor or your local Nordock Inc. representative.

## **Maintenance Procedure**



# **WARNING**

**USE EXTREME CAUTION WHEN INSTALLING THE MAINTENANCE STAND**

**ONLY USE THE PIN PROVIDED TO PROPERLY LOCATE THE MAINTENANCE STAND. SUPPORTING THE LEVELER AT ANY OTHER LOCATION CAN RESULT IN SERIOUS BODILY HARM AND EQUIPMENT DAMAGE.**

**BE SURE THE POWER HAS BEEN DISCONNECTED, THE CONTROL PANEL IS LOCKED OUT AND BOTH LIP AND DECK MAINTENANCE SUPPORTS ARE IN PLACE BEFORE ENTERING THE DOCK LEVELER PIT AREA.**

Before operating or maintaining the dock leveler, read and follow the practices in the Safety Section and all warnings contained in this manual. Failure to follow the guidelines in this manual and those in effect in the workplace can result in serious bodily harm and equipment damage.

1. Raise the dock to its highest position.
2. Raise the lip and use the lip lock to hold the lip in the extended position.
3. Remove the maintenance stand, located on the frame lower outside left side and position one end onto the adjacent pin (on the frame). The stand will slope toward the rear of the dock, but should be kept vertical left or right.

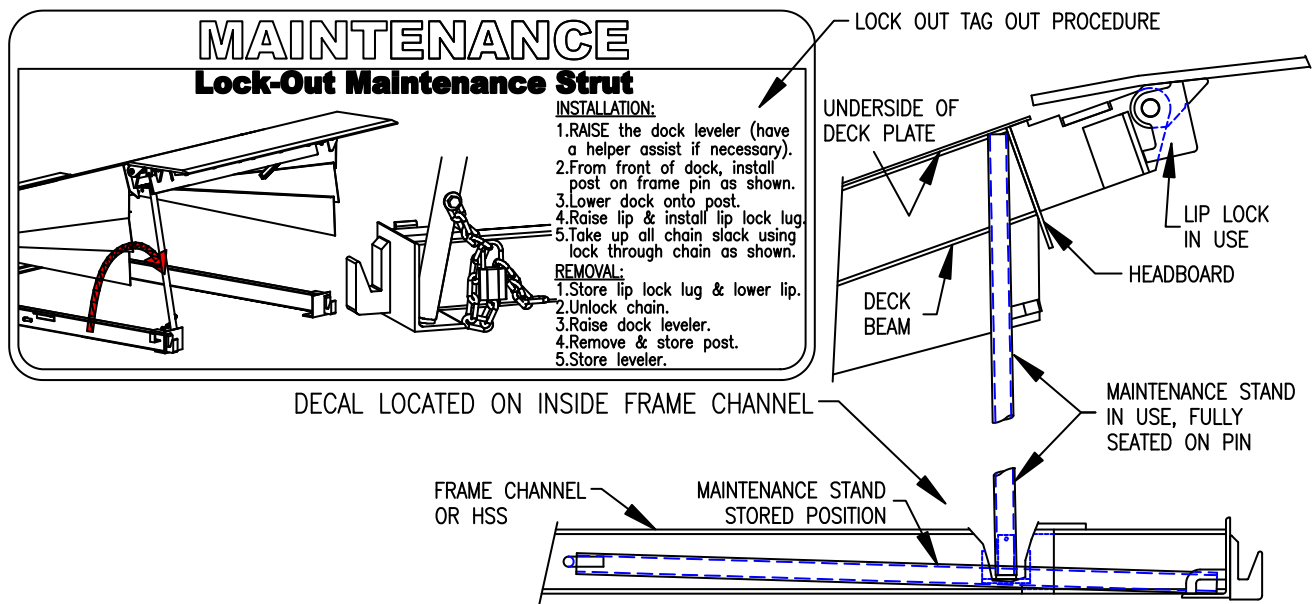

4. Lower the dock onto the stand, making sure the stand supports the deck plate and headboard between the deck beams, as shown. DO NOT support the dock from the bottom of the deck beam.
5. After completing work on the dock, unlock and lower the lip. Remove the maintenance stand and return to its stored position. Do not stand under the dock after the support has been removed.

## Labels

The labels and decals on the dock leveler must be kept in clean, legible condition at all times. The following shows the decals and their placement on the dock leveler. Please check their condition on a daily basis, and replace them immediately if they become unreadable.

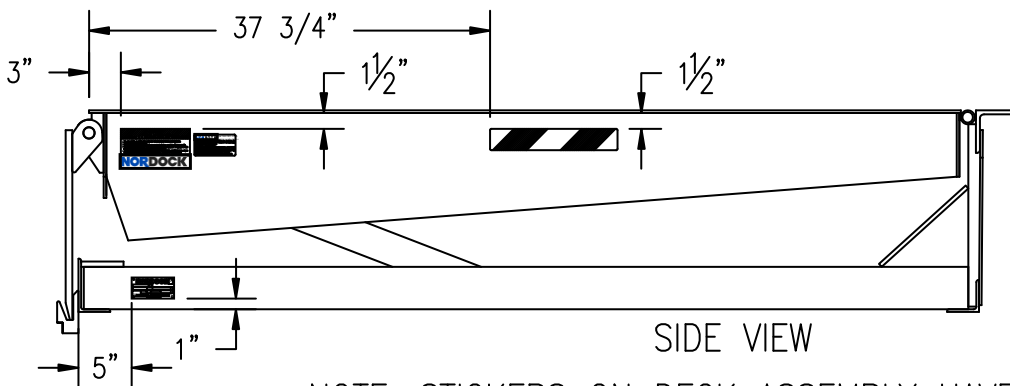
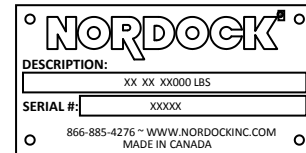
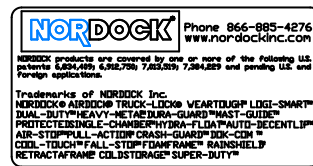
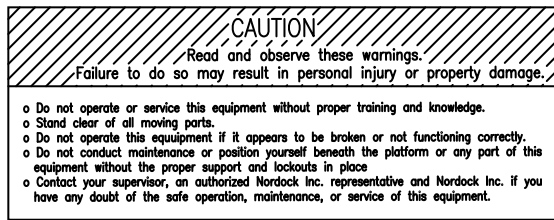

NOTE: STICKERS ON DECK ASSEMBLY HAVE THE SAME PLACEMENT ON BOTH SIDES

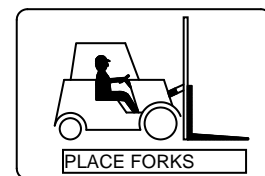
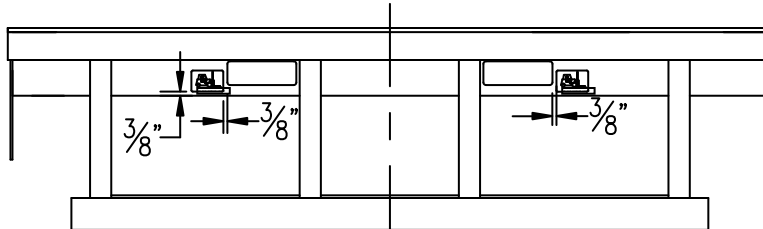

# Installation



## **WARNING**

Before operating or maintaining the dock leveler, read and follow the safety practices contained in this manual. Failure to follow the guidelines in this manual and those in effect in the workplace can result in serious bodily harm and equipment damage.

### **Pit Check**

1. Check the entire pit area for proper construction according to the certified pit drawings. Ensure the pit walls are square and plumb. If this is a replacement, ensure the steel sections are in good, weld-able condition. Check the electrical service running to the pit and make sure it is the same as the voltage and phase as shown on the wiring diagram in the control panel.
2. Complete any pre-wiring procedures before the dock is placed in the pit. Ensure that any cables, plugs or leads are connected to the dock, and that there are correct corresponding leads, receptacles or device boxes with covers in the pit.
3. Make sure that any conduit and/or junction boxes do not interfere with the frame uprights. See pit drawings below for best placement.

### **Dock Installation**

**Note:** When moving the dock leveler in preparation to installation, it is crucial that the unit be moved only using the fork pockets at the rear of the frame.

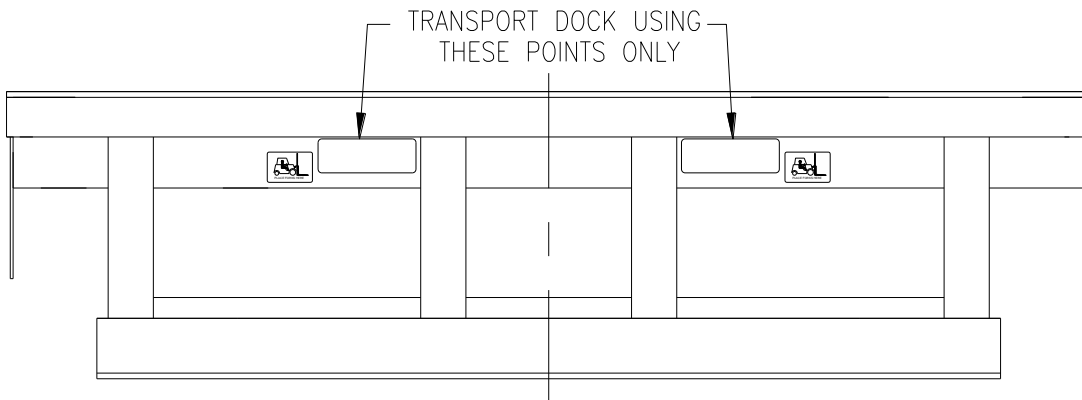

1. Have the control panel mounted and wired by a qualified electrician. See electrical diagram inside the control panel. Wires shown as dashed lines are field connections.



2. Shims must be placed in the following areas for the installation of the dock. Make sure that:

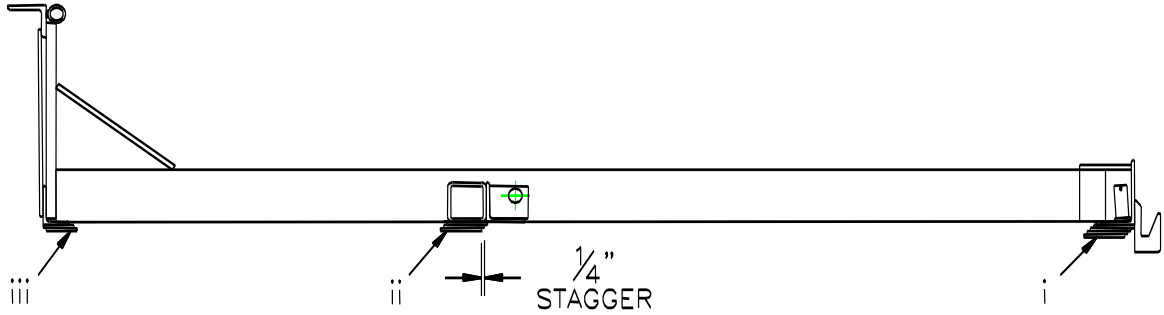

3. Shims must be placed in the following areas:

- I. Under both frame rails directly behind the lip keeper lugs. (2 places)
  - II. Under the cross tube where the cylinder mounts to the frame.  
(1 place-60K Dock) (2 places 80K-150K Dock)
  - III. Under frame angle at the uprights connecting to the hinge angle. (4 places).
- Also shim under the maintenance support stand bracket.

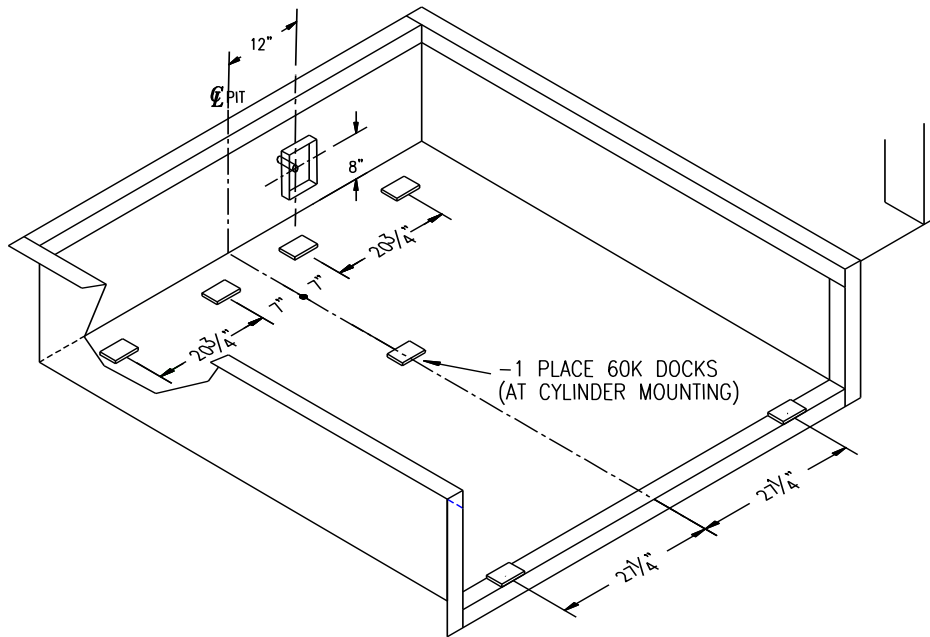

**60K PIT**

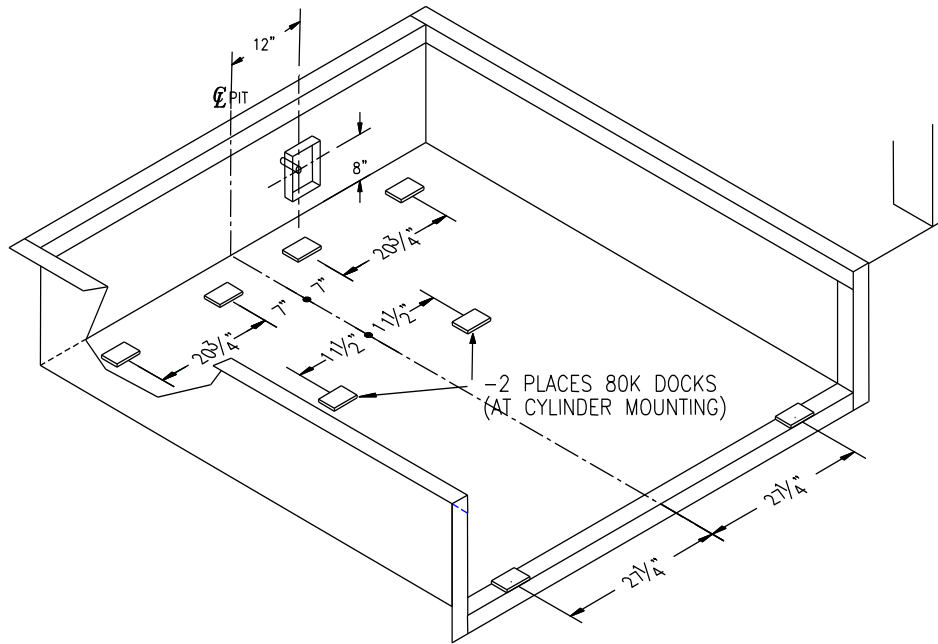

**80K PIT**

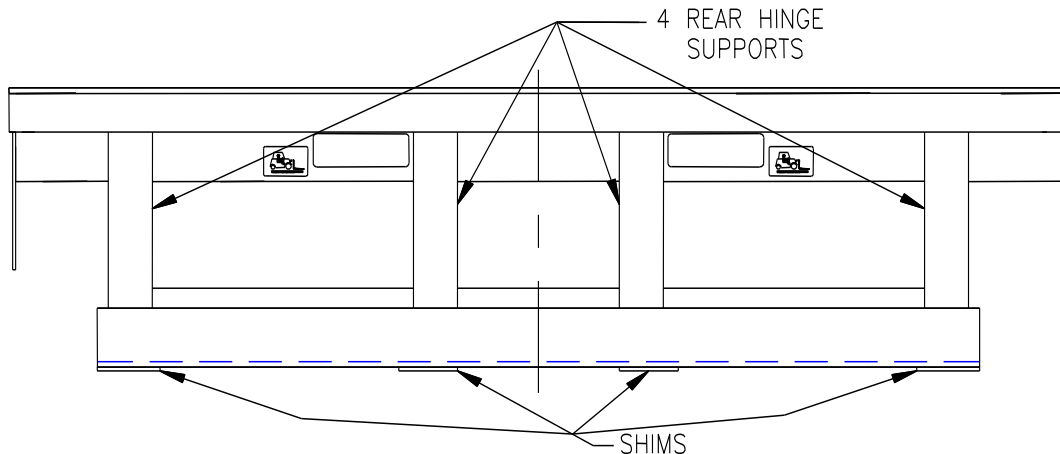

4. Remove straps holding electrical cable and attach plug (not included).  
Temporarily strap cable to rear frame upright so that it can be easily reached to connect to pit outlet.

**Note:** All lifting chains must be minimum grade 80 and chain hooks have a minimum 1-ton capacity. An endless master link should also be used to assist in the levelling of the dock leveler.

5. Attach the lifting chains to the front of dock leveler and a swivel hoisting to the rear of the dock leveler in the 3/4"-10 threaded rear center hole. Three chains must be used; one hooked at the center of the hinge angle, two hooked on the front deck plate outside the second set of lip lugs from the sides of the deck. Attach the chains so that the master link is approximately 12" forward of the center of the deck, and centered along the width. See picture next page.

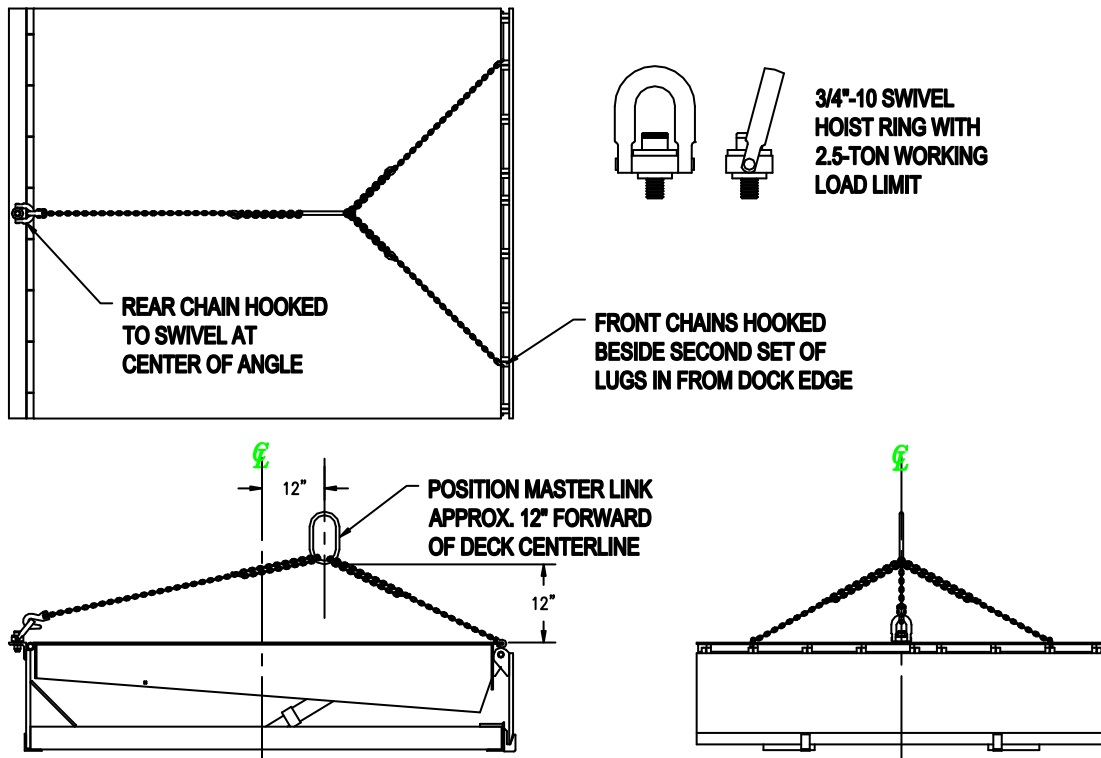

6. Lift the deck approximately 6" and check that it is level. Adjust chains accordingly if required. Do not attempt to install the dock if it is not level. Damage to the unit or personal injury may result.
7. Place dock into pit. Leave room between the dock leveler and the rear pit wall so that the electrical connections can be made.
8. Connect dock leveler to the source connection in the pit area. Ensure that when the dock leveler is pushed into place that the dock does not crush the cord.
9. Move dock so that hinge angle should fit flush and tight to pit angle and be centered between side pit curb angles.

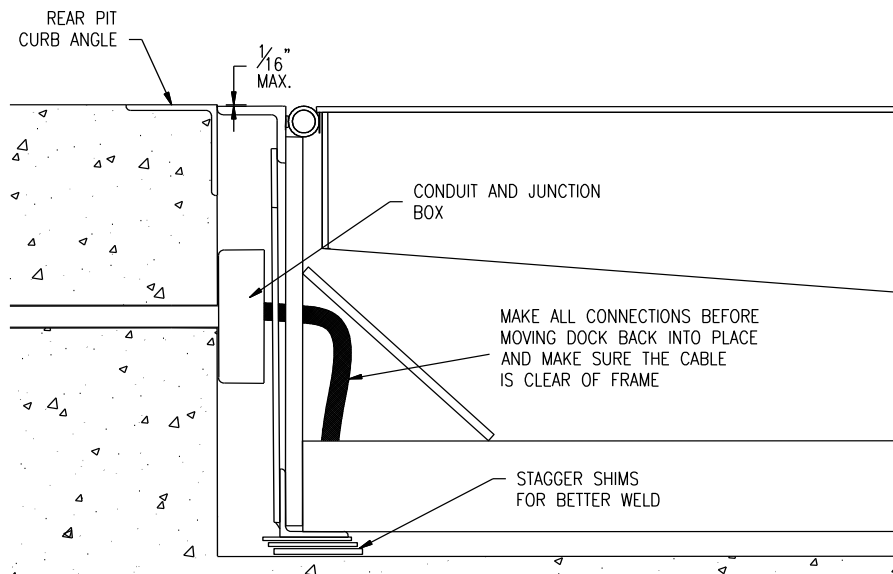

10. Remove the transport cables and raise the dock leveler. Install the maintenance supports and check the position of the shims. Re-position if necessary. There should be no more than 1/16" in height difference at any point between the pit curb angle and the dock leveler. Tack-weld the hinge angle to the pit curb angle.
11. Remove the maintenance support and lower the dock to its stored position. Check that the dock is still squarely positioned and level with the pit sides. Add or remove shims as necessary. See also Maintenance Procedure, page 5 of this manual.

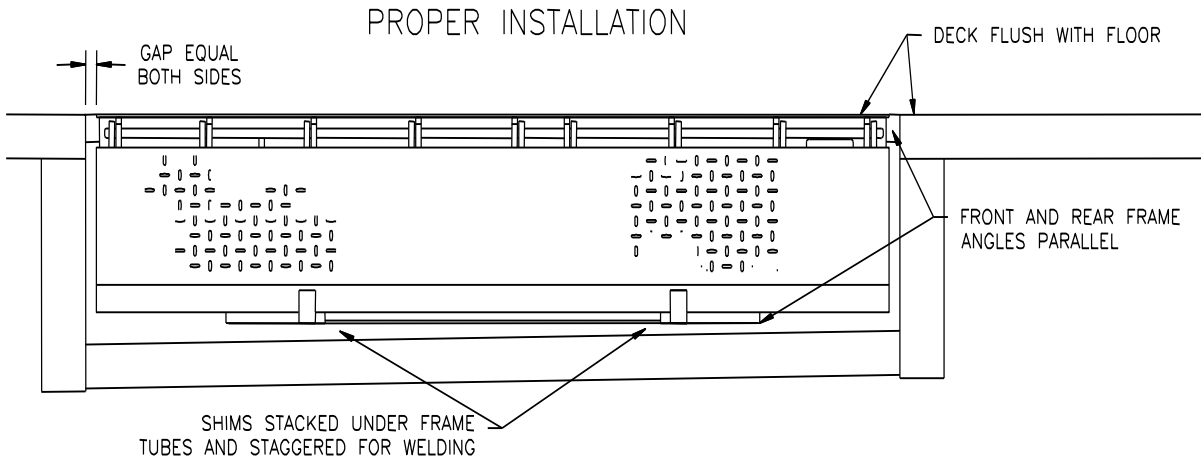

12. Raise the deck and re-install the maintenance support. Weld the shims solidly together, and weld the shims to both the frame and the front angle.
13. Weld the rear hinge angle to the rear and side pit curb angles as shown below

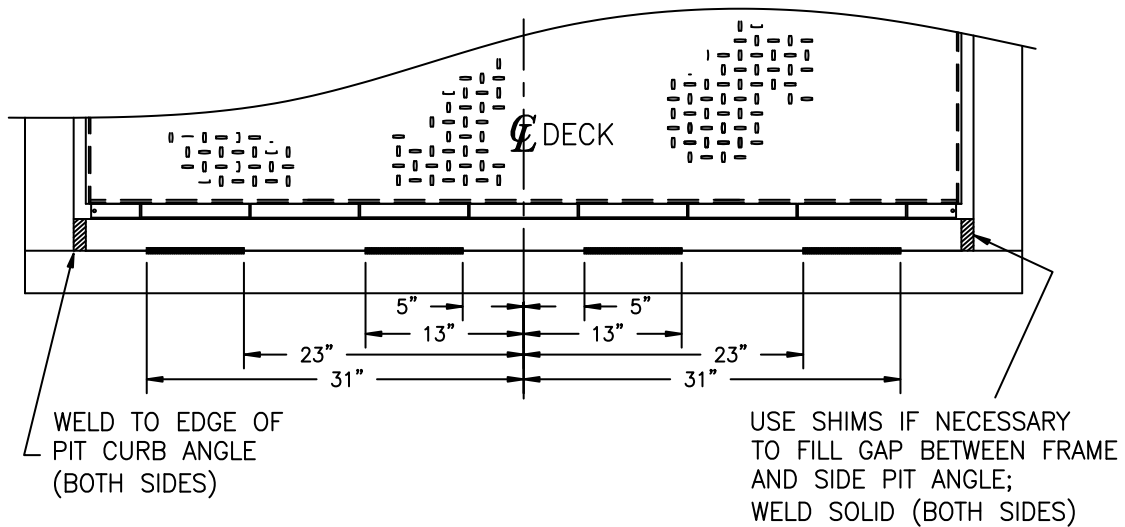

14. Match drill the 1" dia. holes on the frame cylinder mounting angle into the pit concrete. Use 3/4" x 5 1/2" long wedge type anchors supplied to secure. (4 places 60K capacity and larger docks)

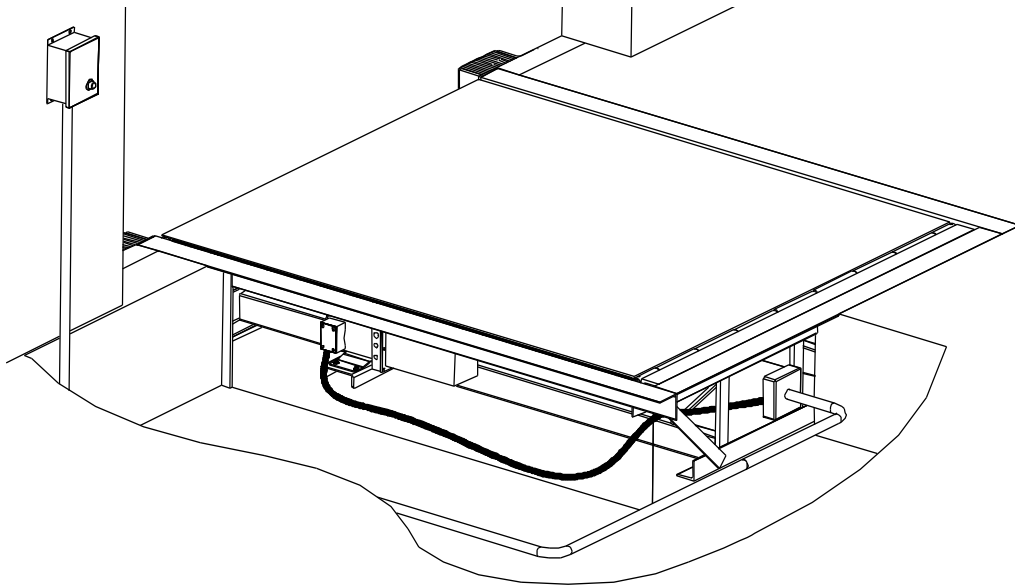
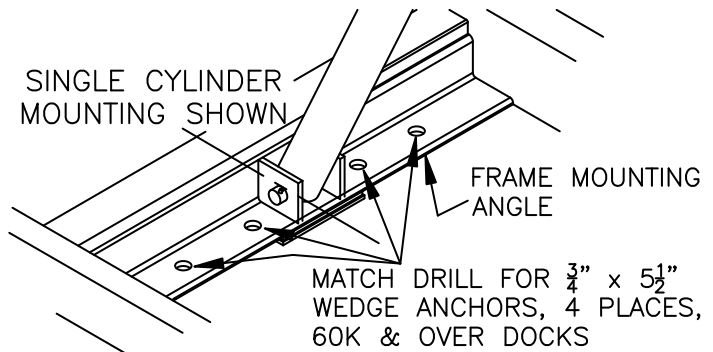

Correct installation will ensure consistent, efficient operation for many years to come.

**Note:** It is the installer's responsibility to complete any paint touch-up and dock area clean up that may be required.

## **Bumper Install**

Bumpers should be installed as follows to prevent damage from trucks backing into the dock leveler.

Install bumper so that it is 1/4" below floor level for proper securing, and 3/4" away from the edge of the pit so that the heads of the bolts will clear the lip as it passes the bumper.

Weld the bumper wherever possible to the pit curb angle, and use 5/8" x 4 1/2" wedge anchors (not supplied) in the angle holes.

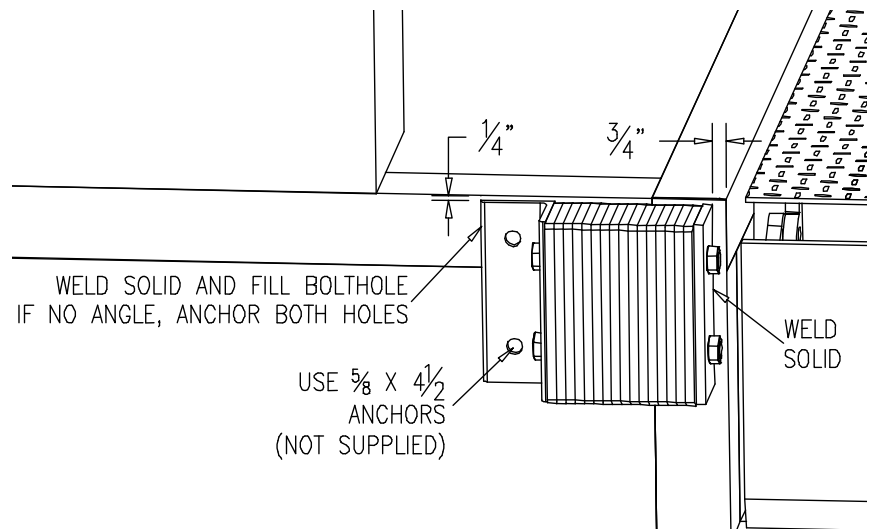

## Operation



### **WARNING**

Before operating or maintaining the dock leveler, read and follow the safety practices contained in this manual. Failure to follow the guidelines in this manual and those in effect in the workplace can result in serious bodily harm and equipment damage.

**Note:** If the truck to be serviced is below dock level, please see the additional instructions for Below Dock Control in this section.

### **Standard (Single Pushbutton) Control Panel**

1. Push and hold the “RAISE” button. The ramp will rise and the lip will extend once the deck has reached its highest point. Release the button once the lip has extended and the deck will lower and rest on the truck bed.
2. Proceed with loading and/or unloading.
3. To return the dock leveler to its stored position, push and hold the “RAISE” button until the lip clears the truck bed. The lip will fold and when the button is released, it will return to its stored position.
4. Ensure the lip is seated in the lip keepers before walking or driving on the dock.

### **Below Dock Control**

To lower the ramp without extending the lip for loading below dock level, substitute item 1 in the preceding instructions with the following:

- 1a. Press the “RAISE” button until the ramp reaches its highest point and the lip extends approximately 2”.
- 1b. The ramp will lower below level and rest on the bed. Do not walk or drive on the dock until it has completely stopped lowering.

### **Optional (Lip Extend and/or On/Off Switch) Control Panel**

1. If equipped, turn the ON/OFF switch to the ‘ON’ position, and pull the emergency stop pushbutton out.
2. Push and hold the “RAISE” button. The ramp will rise and once the lip has cleared the deck of the truck, press the “EXTEND” button to push the lip out. Release the button once the lip has extended and the deck will lower and rest on the truck bed.

3. Proceed with loading and/or unloading.
4. To return the dock leveler to its stored position, push and hold the “RAISE” button until the lip clears the truck bed. The lip will fold and when the button is released, it will return to its stored position.
5. Ensure the lip is seated in the lip keepers before walking or driving on the dock.
6. Push in the “STOP” button and turn the ON / OFF button to the “OFF” position (if equipped).

### **Below Dock Control**

To lower the ramp without extending the lip for loading below dock level, substitute item 2 in the preceding instructions with the following:

2a. Press the “RAISE” button until the ramp clears the keepers and the truck bed by approximately 6” and release the button.

2b. Before the ramp returns to the keepers, press the “EXTEND” button to extend the lip approximately 2” out from it’s resting position. Release the button and the dock will rest on the below dock supports. Do not walk or drive on the dock until it has completely stopped lowering.

### **Auto Return**

In the event a truck pulls away from the dock before the lip is stored, the auto return feature will raise the ramp for a set time and the lip will store automatically. If this occurs check that the lip has stored properly on the lip store lugs, and it is recommended that all safety practices be reviewed.

**Note:** If the dock leveler is equipped with an auto return feature it is necessary to turn the selector button to the “OFF” position to perform the below dock control function. Follow the instructions and turn the selector to “OFF” as the ramp approaches full below dock position. Turn the switch to the “ON” position only when loading or unloading is complete, and all persons, equipment and material are cleared from the dock.

## Maintenance and Lubrication



### WARNING

Before operating or maintaining the dock leveler, read and follow the safety practices contained in this manual. Failure to follow the guidelines in this manual and those in effect in the workplace can result in serious bodily harm and equipment damage.

**Note:** Use only the lubricant grades specified in this manual. Failure to use the materials listed may lead to premature failure, and will void any warranty claims for the dock leveler.

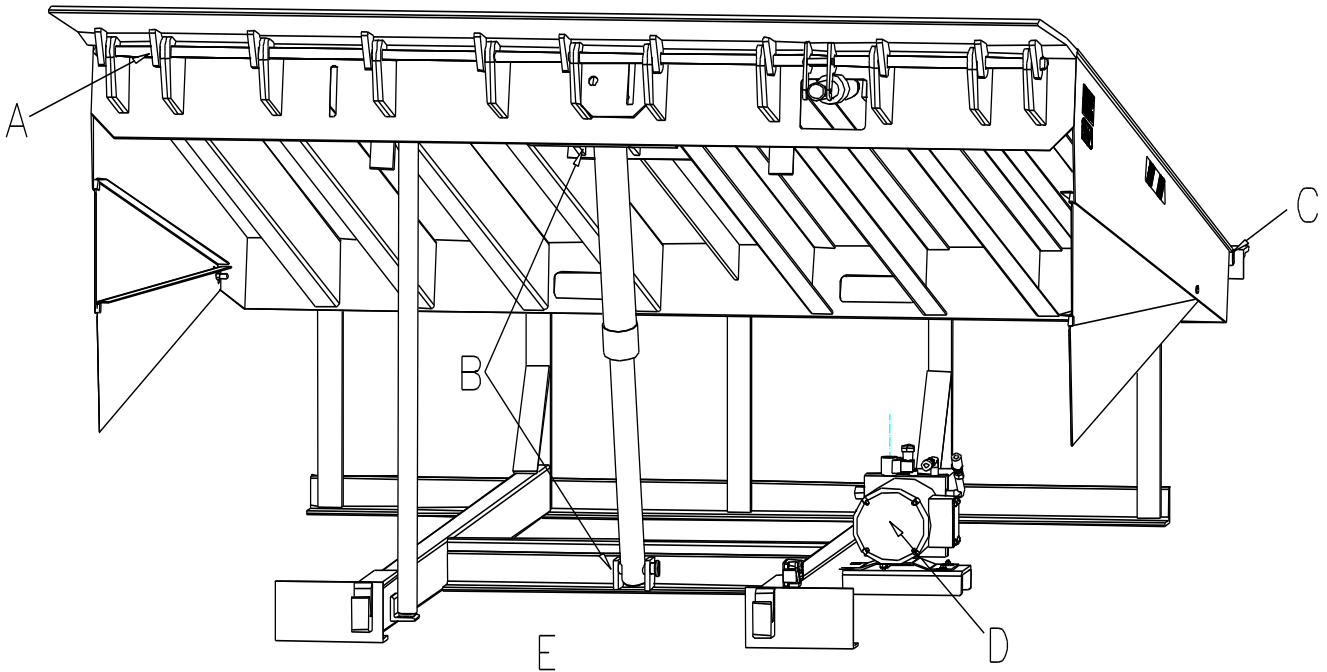

Item	Lubrication	Adjustment	Cleaning
- A - Lip Hinge	Every 90 days Using grease	None	Remove debris as required
- B - Cylinder Pivot Pins	Every 90 days Using light oil	None	Remove debris as required
- C - Dock Hinge	Every 90 Days Using light oil	None	Remove debris as required
- D - Hydraulic Oil Reservoir	Check level daily Change oil yearly	None	Remove and clean strainer and magnet yearly
- E - Pit Area	None	None	Every 90 days or as required to remove debris



## **Acceptable Lubricants and Oils**

### Hydraulic

Oils used in the hydraulic system must meet minimum ISO grade 22 standard. E.G.:

COMMERCIAL OIL MULIT-VIS MV22  
 MOBIL AERO HFA (49011)  
 EXXON UNIVIS GRADE J13  
 TEXACO AIRCRAFT OIL #1537BB  
 U.S.OIL CO. #5606 (LOW TEMP)  
 SHELL TELLUS T22

**Optional** biodegradable oils (Nordock PN 13-0807) are E.G.:

Greenland ES Green Plus  
 Forsythe 6282/B2 Power Flo

### Grease

Grease used for hinges must meet a minimum EP-2 grade. E.G.:

CHEVRON DURA-LITH EP-2

### Light Oil

Light oils used should have good penetration and adhesion qualities.

## **Hydraulic Adjustment**

**Note:** Power units are set at the factory to optimum performance. Adjustment is rarely necessary and should only be performed by a qualified hydraulic technician.

To make adjustments: Remove the outer cap, as required, and loosen the locknut.  
 Use the chart below as an adjustment guide.

Item numbers below refer to Parts and Service Section 3 – Power Pack

Item	Name / Function	Adjustment
10	<b>Sequence Valve</b> (Blue Cap) -Sends flow to the lip cylinder when deck is at full height	-Required if lip extends before the deck raises. -Turn adjustment screw clockwise to control the lip extend. -Adjust in 1/8 turn increments.
11	<b>Pressure Relief Valve</b> (Red Cap) -controls maximum pressure	-Required if having motor stalling problems. -Turn counter-clockwise (loosen) to lower relief pressure. -Adjust in 1/8 turn increments.
12	<b>Flow Control Valve</b> -controls downward speed of deck.	-Turn adjustment screw clockwise (tighten) to slow speed or turn counter-clockwise (loosen) to increase speed. -Adjust in 1/8 turn increments.

For all- Retighten locknut and replace cap, if applicable, after adjustment is complete.

## Parts and Service Tables

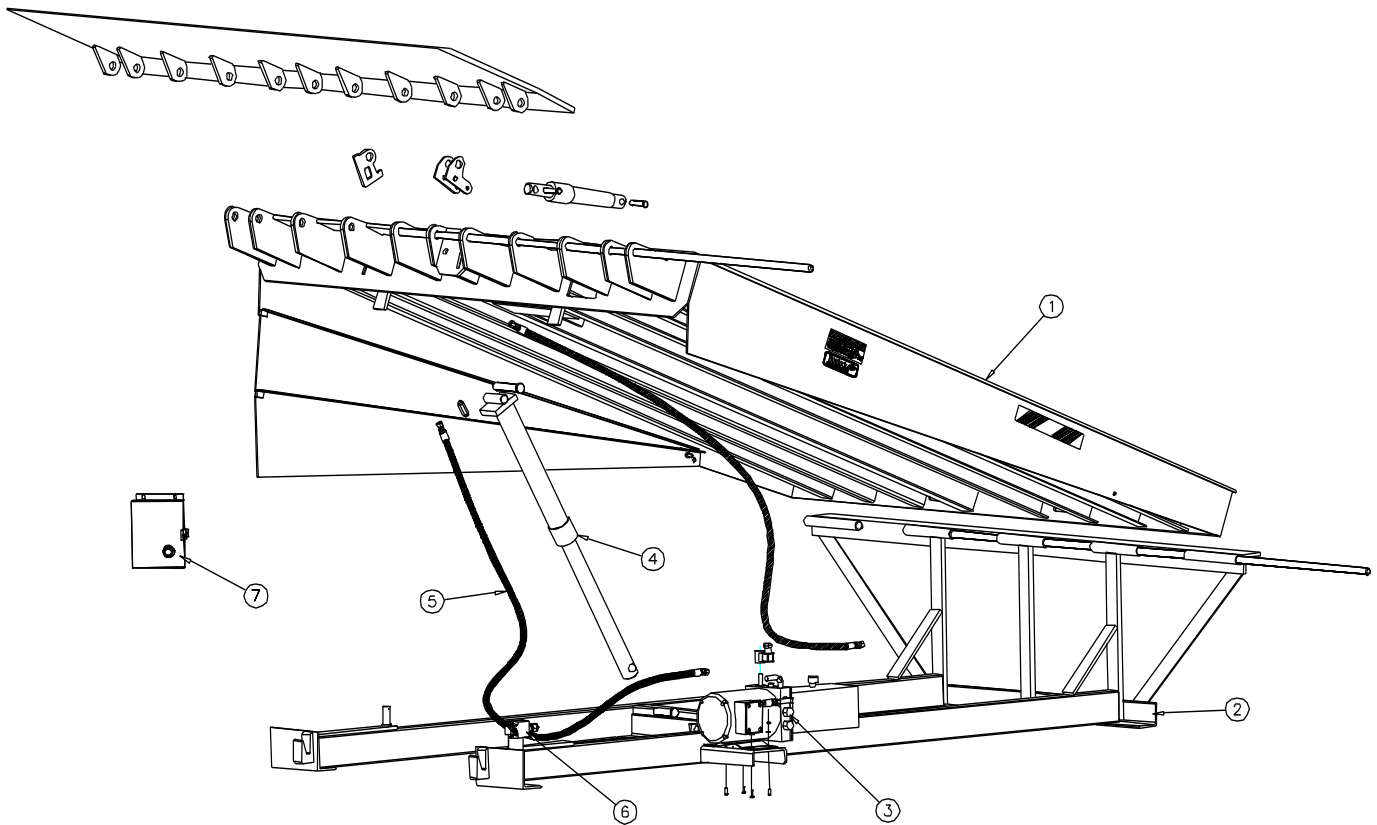

Item Number/ Section	Description
1	Deck and Lip Assembly
2	Frame Assembly
3	Power Pack and Related Hydraulic Components
4	Hydraulic Cylinders
5	Hydraulic Lines and Fittings
6	Optional Equipment
7	Control Panel

**Note:** Not all parts and weldments are noted in this manual. Only those that are serviceable and /or replaceable will be listed. For additional information on those parts not included in this manual, please contact Nordock. Remember to make note of the model and serial number of the unit for accurate parts and service.

## Section 1 – Deck and Lip Assembly

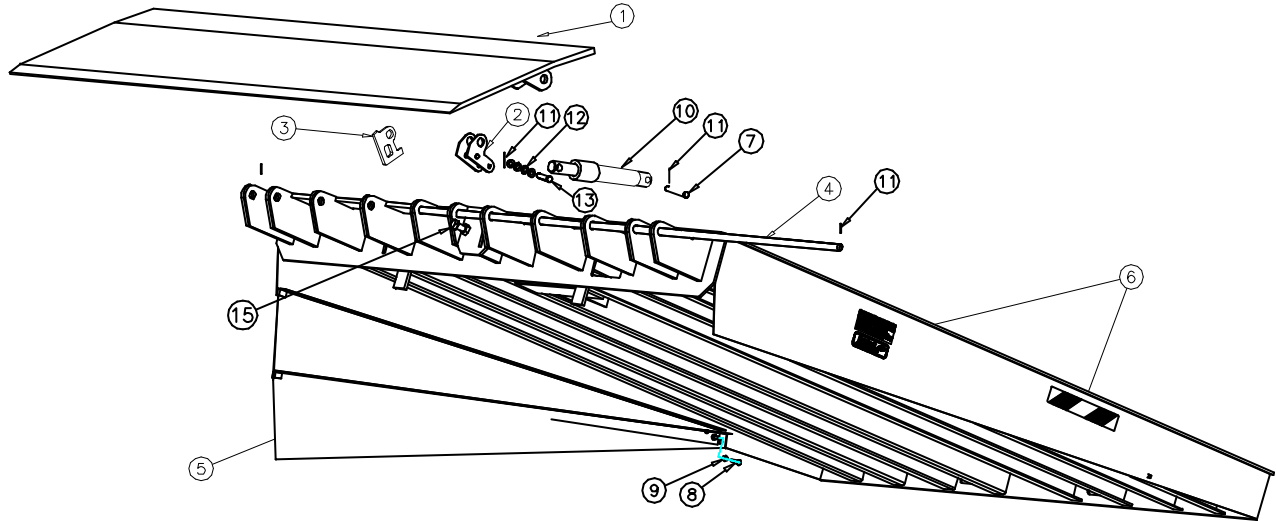

Item	Qty.	Description / Model						Note	
1	1	Lip Weldment		P/N				C/F	
		Cap.	Length	6'	6.5'	7'	7'T		70"
		60K	16"	42-1439		42-1547	42-1496		
			18"	42-1440		42-1548	42-1497		
			20"	42-1441		42-1549	42-1498		
80K	16"	42-1555	42-1587	42-1364	42-1572				
	18"	42-1556	42-1588	42-1365	42-1573				
	20"	42-1557	42-1589	42-1366	42-1574				
		P/N							
2	1	Lip Cam Weldment			60-100K		42-0738		
3	1	Lip Safety Lock Lug			60-80K		43-1036		
4	1	Hinge Rod			6' Wide Docks, 60K		43-0151		
					6.5' Wide Docks, 60K		43-0152		
					7' Wide Docks, 60K		43-0153		
					6' Wide Docks, 80K		43-0691		
					6.5' Wide Docks, 80K		43-0692		
					7' Wide Docks, 80K		43-0693		
5	1	Telescoping Side Skirt Kit – 6'					42-0393		
		Telescoping Side Skirt Kit – 8'					42-0394		
		Telescoping Side Skirt Kit – 10'					42-0395		
6	1	Dock Leveler Decal Kit					42-0392	1	
7	1	Cylinder Mount Pin, Clevis Pin 1/2" CRR x 4 1/2" Long					13-3672		
8	2	Bolt, 3/8" - 16 UNC x 1 1/4" Carriage Head					13-0122		
9	2	Nut, 3/8" - 16 Grade 5, Nylock					13-0707		
10	1	Lip Cylinder - 1 1/2"					C1-0009		
		Seal Kit - 1 1/2"					C3-0025		
11	1	Cotter Pin, 1/8" x 1"					13-0171		
12	4	Washer, 1/2" Flat					13-0267		
13	1	Clevis Pin, 1/2" x 3 1/2"					13-0399		
14	2	Bolt, Hex 5/8-11NC x 4" thread full length 60-80K Docks					13-0302		
15	2	Roll Pin, 1/4" x 1 1/2"					13-0313		

**NOTE 1:** – For correct decal placement, see safety section.

## Section 2(a) – 60K Frames

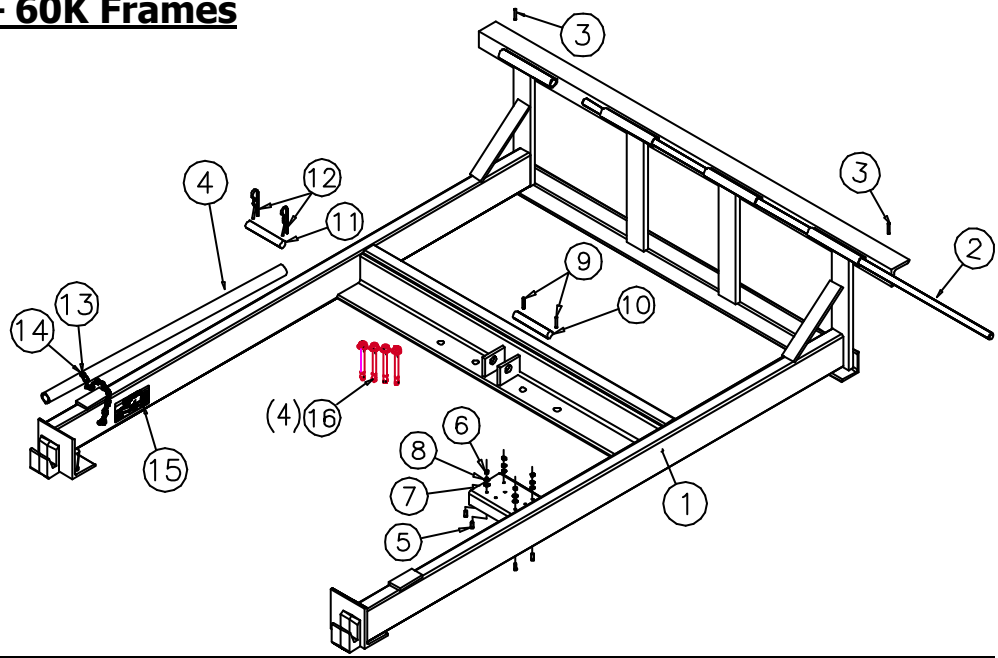

Item	Qty.	Description / Model	P/N 19" Frame	P/N 23" Frame	Note	
1	1	Frame Weldment 60K	6 X 6		42-3496	1
			6 X 8		42-3497	
			6 X 10		42-3498	
			6.5 X 6			
			6.5 X 8			
			6.5 X 10			
			7 X 6	42-3466	42-3463	
7 X 8	42-3467	42-3464				
7 X 10	42-3468	42-3465				
2	1	Hinge Rod	6' Wide Docks 6.5' Wide Docks 7' Wide Docks	43-0447 43-0448 43-0449		
3	2	1/4" x 2" Roll Pin		13-0555		
4	1	Maintenance/Support Stand	All 19" Frames and 10' Long 23" Frames 6' & 8' Long 23" Frame	43-0600 43-0600 43-0262		
5	4	Bolt, Hex, 1/4"-20 UNC x 1, Plated		13-0623		
6	4	Nut, 1/4"-20 UNC, Plated		13-0334		
7	4	Washer, 1/4"-SAE Flat, Plated		13-0272		
8	4	Washer, 1/4" Lock, Plated		13-0335		
9	2	Cotter Pin, 1/4" x 1 3/4"		13-0992		
10	1	Lower Cylinder Mount Pin, 5 1/4" long Optional St. St. Pin		43-0311 43-1035		
11	1	Upper Cylinder Mount Pin, 6 3/4" long Optional St. St. Pin		43-0310 43-1027		
12	2	Hairpin Cotter, 7/8" Eye x 4" Long, Plated		13-3579		
13	1	Washer, 1/4" Fender, Plated		13-0271		
14	1	Screw, 1/4" -14 x 1, Tek, Hex Head, plated		13-0273		
15	1	Decal, Dock leveler, Lock-Out Tag-Out		43-1287		
16	4	Anchor, Wedge, 3/4" x 5 1/2" long, plated		13-4569		

**Note 1 – The standard rear frame angle width is 4". Angle widths may vary to suit pit length. Please consult factory when ordering replacement frames.**

**Section 2(b) – 80-100K Frames**

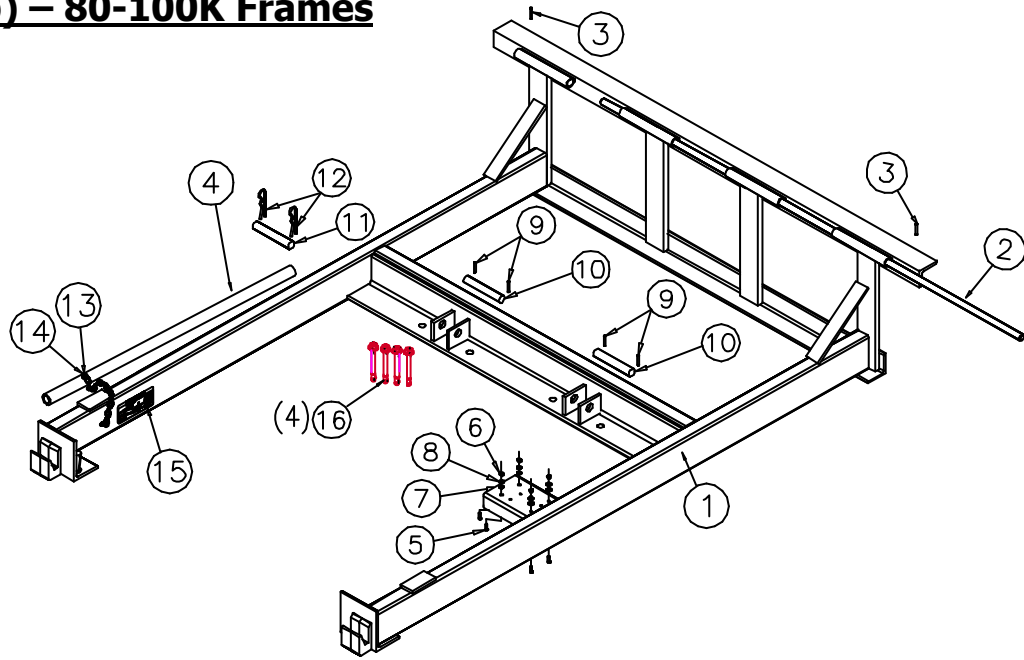

Item	Qty.	Description / Model	19" Frame	23" Frame	Note	
1	1	Frame Weldment	6 X 6	42-3493	42-3487	1
			6 X 8	42-3494	42-3488	
			6 X 10	42-3495	42-3499	
			6.5 X 6		42-3490	
			6.5 X 8		42-3491	
			6.5 X 10		42-3492	
			7 X 6	42-3457	42-3478	
			7 X 8	42-3458	42-3479	
		7 X 10	42-3459	42-3480		
2	1	Hinge Rod, 60-100K	6' Wide Docks		43-0447	
			6.5' Wide Docks		43-0448	
			7' Wide Docks		43-0449	
3	2	Roll Pin, 1/4" x 1 1/2"		13-0313		
4	1	Maintenance/Support Stand	All 19" Frames		43-0600	
			10' Long 23" Frame		43-0600	
			6' & 8' Long 23" Frame		43-0262	
5	4	Bolt, Hex, 1/4"-20 UNC x 1, Plated		13-0623		
6	4	Nut, 1/4"-20 UNC, Plated		13-0334		
7	4	Washer, 1/4"-SAE Flat, Plated		13-0272		
8		Washer, 1/4" Lock, Plated		13-0335		
9	4	Cotter Pin, 1/4" x 1 3/4" long		13-0992		
10	2	Lower Cylinder Mount Pin, 4 1/2" long Optional St St Pin		43-0312		
				43-1028		
11	2	Upper Cylinder Mount Pin, 6 3/4" long Optional St St Pin		43-0310		
				43-1027		
12	4	Hairpin Cotter, 7/8" Eye x 4" Long, Plated		13-3579		
13	1	Washer, 1/4" Fender, Plated		13-0271		
14	1	Screw, 1/4" -14 x 1, Tek, Hex Head, plated		13-0273		
15	1	Decal, Dock leveler, Lock-Out Tag-Out		43-1287		
16	4	Anchor, Wedge, 3/4" x 5 1/2" long, plated		13-4569		

**Note 1 – The standard rear frame angle width is 4". Angle widths may vary to suit pit length. Please consult factory when ordering replacement frames.**

## Section 3 – Power Pack and Related Hydraulic Components

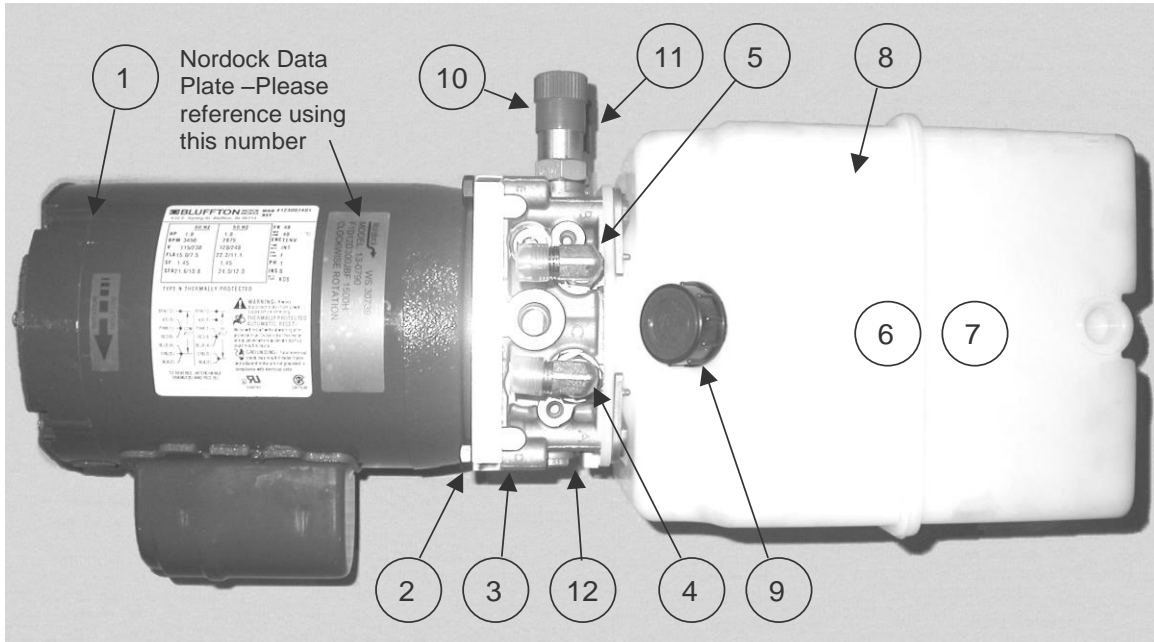

Item	Qty.	Description / Model		P/N	Note
		Complete Power Pack Assembly (Pts 1-12 below)	115 / 230 V 1 Ph 230 / 460 V 3 Ph 575 V 3 Ph	13-0793 13-0794 13-0795	
<b>Power Pack Components:</b>					
1	1	Drive Motor	115 / 230 v. 1 PH 230 / 460 v. 3 PH 575 v. 3 Ph		1
2	1	Motor Coupler	Standard Duty		
3	1	Manifold Assembly	Standard Duty		
4	1	Hydraulic Coupler, 90° FSwivel 3/8" NPT to #6 MJIC, Deck Lift Port			
5	1	Hydraulic Coupler, 90° FSwivel 3/8" NPT to #6 MJIC, Lip Extend Port			
6	1	Pump Assembly (Inside Tank)			
7	1	Oil Pickup Screen and Tube (Inside Tank)			
8	1	Hydraulic Oil Reservoir		13-2824	
9	1	Filler / Vent Cap		13-3596	
10	1	Sequence Valve Cartridge		13-2419	
11	1	Pressure Relief Valve Cartridge		13-3332	
12	1	Flow Control Valve, Adjusting Needle w O-Ring & Nut		13-3341	

**Note 1 – Consult factory when ordering individual power pack components.**

## Section 4 – Hydraulic Cylinders

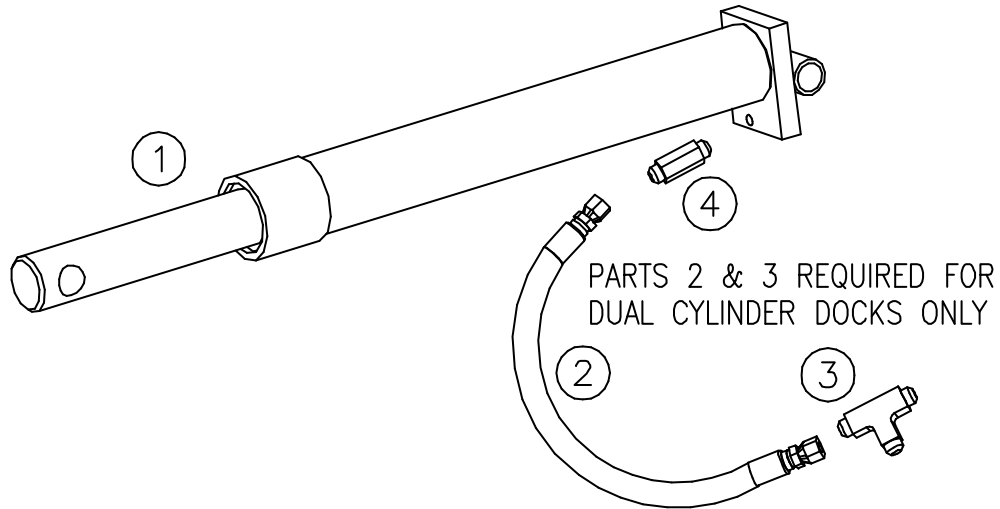

Item	Qty.	Description	Capacity	Dock Length	Stroke	P/N	Note
1	1	Deck Lift Cylinder, 3" Diameter	60K, 160K	6'	17"	C1-0007	1
				8'	17"		
				10'	20"		
	1	Seal Kit, 3"	60K, 160K	All		C3-0013	
2	2	Deck Lift Cylinder, 2" Diameter	80-120K	6'	17"	C1-0011	2
				8'	17"		
				10'	20"		
	2	Seal Kit, 2"	80-120K	All		C3-0020	
2	2	Hose, required for Dual cylinder docks only, #6 with 2 straight FJIC ends		80-120K Dock x 15" lg. 160K Dock x 20" lg.		42-3817 42-3818	
3	1	Tee Fitting (dual cylinder docks only), #6 JIC				13-0185	
4	A/R	Velocity Fuse (1 required per cylinder)		80-120K Docks, 3 gpm		13-0306	
				60K, 160K Docks, 10 gpm		13-0307	

**Note 1:** 160K Dock uses 2-3" Dia. Cylinders      **Note 2:** 80K to 120K Docks use 2-2" Dia. Cylinders

## Section 5 – Hydraulic Lines and Fittings

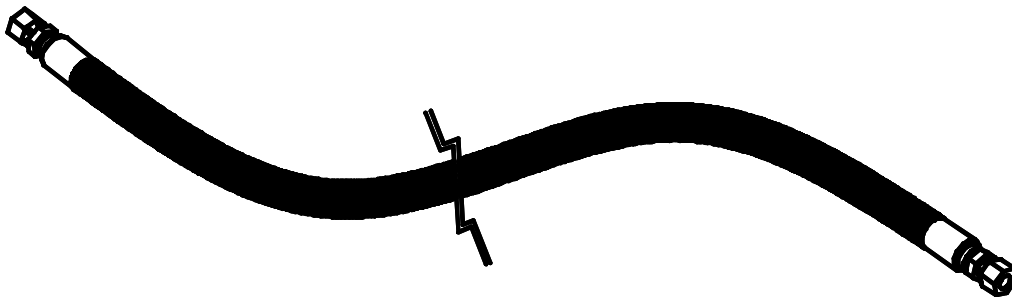

Dock length	Dia.	Description / Model	P/N	Note
6'	3/8"	Deck Lift, x 72" long	42-0383	1
		Lip, ..... x 48" long	42-0386	
		Hose kit, consisting of 1 each above hoses	13-1678	
8'	3/8"	Deck Lift, x 75" long	42-0384	1
		Lip, ..... x 54" long	42-0387	
		Hose kit, consisting of 1 each above hoses	13-1677	
10'	3/8"	Deck Lift, x 87" Long	42-0385	1
		Lip, ..... x 78" long	42-0388	
<b>Emergency Stop:</b>				
All	3/8"	Tank to Valve, 18" Long	13-3370	1
6'	3/8"	Deck Lift, 58" Long	42-1354	
8'	3/8"	Deck Lift, 61" Long	42-1353	
10'	3/8"	Deck Lift	42-1363	
<b>Optional Remote Mount Power Pack, standard length:</b>				
All	3/8"	Deck Lift & Lip, x 20'-0" long (2 hoses)	42-1545	1

**Note 1: All hoses are #6 with 2 straight FJIC ends**

**Lip Extend/Emergency Stop Valve:**

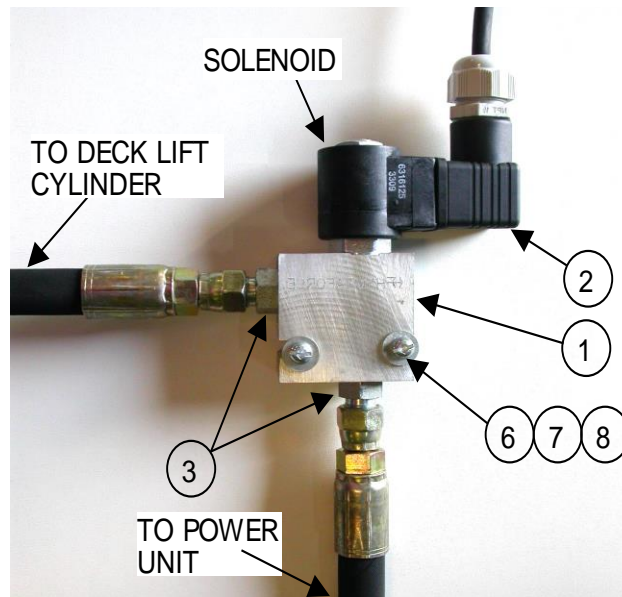

Item	Qty.	Description / Location	P/N	Note
1	1	Solenoid Valve / Rear Frame Brace	13-0826	
		Complete Assembly Solenoid only	13-0595	
2	1	Receptacle, solenoid valve, Hershman	13-2371	
3	2	Hydraulic Fitting, Str. #6 JICM / 9/16 M ORB	13-0609	
4	1	Pushbutton / Control Panel, Lip Extend (not shown)	13-0317	
5	1	Mushroom Pushbutton, / Control Panel, Emergency Stop Button (not shown)	13-0318	
6	2	Screw, #10-24 x 1 1/2" long, plated, combo head	13-0274	
7	2	Washer, Lock, #10, plated	13-0948	
8	2	Washer, Flat, #10, plated	13-1956	

**Note: See Section 5 for the hydraulic lines required for the Lip Extend/Emergency Stop valve.**



## **Section 6 – Optional Equipment**

Option	Qty.	Description / Location	P/N	Note
Auto Return	1	Limit Switch / Located on Frame Rail	13-0298	
	1	Timer / Control Panel	13-0156	
	1	On / Off Selector / Control Panel	13-0316	
Dock Store	1	Limit Switch / Located on Frame Rail	13-0298	
Bumpers	2	Standard Bumper, AF410-11	61-0001	1
Weather Seals	6'	Brush Seal and Mounting Extrusion Kit	13-0025	
	8'	Brush Seal and Mounting Extrusion Kit	13-0024	
	10'	Brush Seal and Mounting Extrusion Kit (3 pc)	13-0024	
Remote Mount Power Pack	1	Wall Mount Bracket	43-0428	
	4	Bolt, Hex, 1/4" – 20 UNC x 1"	13-0623	
	4	Nut, 1/4" – 20 UNC, Plated	13-0334	
	4	Washer, 1/4" SAE Flat	13-0272	
	4	Washer, 1/4" Lock	13-0335	

**Note 1 – For custom bumper sizes and applications, please contact your nearest Nordock representative or call 1-866-885-4276.**

## **Section 7 – Control Panels**

Volts/Ph.	Description / Style	P/N	Note
115/1/60	Standard, 3 Button – Deck Raise, Lip Extend, and Emergency Stop	13-1132	
	Optional: 4 Button – Deck Raise, Lip Extend and Emergency Stop, Auto Return	13-1350	
208/1/60	Standard, 3 Button – Deck Raise, Lip Extend, and Emergency Stop	13-2625	
	Optional: 4 Button – Deck Raise, Lip Extend and Emergency Stop, Auto Return	13-3017	
230/1/60	Standard, 3 Button – Deck Raise, Lip Extend, and Emergency Stop	13-2626	
	Optional: 4 Button – Deck Raise, Lip Extend and Emergency Stop, Auto Return	13-1982	
208/3/60	Standard, 3 Button – Deck Raise, Lip Extend, and Emergency Stop	13-2402	
	Optional: 4 Button – Deck Raise, Lip Extend and Emergency Stop, Auto Return	13-1243	
230/3/60	Standard, 3 Button – Deck Raise, Lip Extend, and Emergency Stop	13-2382	
	Optional: 4 Button – Deck Raise, Lip Extend and Emergency Stop, Auto Return	13-3574	
460/3/60	Standard, 3 Button – Deck Raise, Lip Extend, and Emergency Stop	13-2500	
	Optional: 4 Button – Deck Raise, Lip Extend and Emergency Stop, Auto Return	13-2426	
575/3/60	Standard, 3 Button – Deck Raise, Lip Extend, and Emergency Stop	43-0261	
	Optional: 4 Button – Deck Raise, Lip Extend and Emergency Stop, Auto Return	13-3784	

**Note 1 – All panels higher than 115V have a reduced voltage secondary to 115V.**

## Wiring Diagrams

The following wiring diagrams may be wired in conjunction with other systems used with the dock leveler. Please consult Nordock Inc. or a qualified electrician before performing any work on the control panel or its components.

### Single Phase 3 Button 115v - Starter, Lip Out and Emergency Stop

48-0040-B

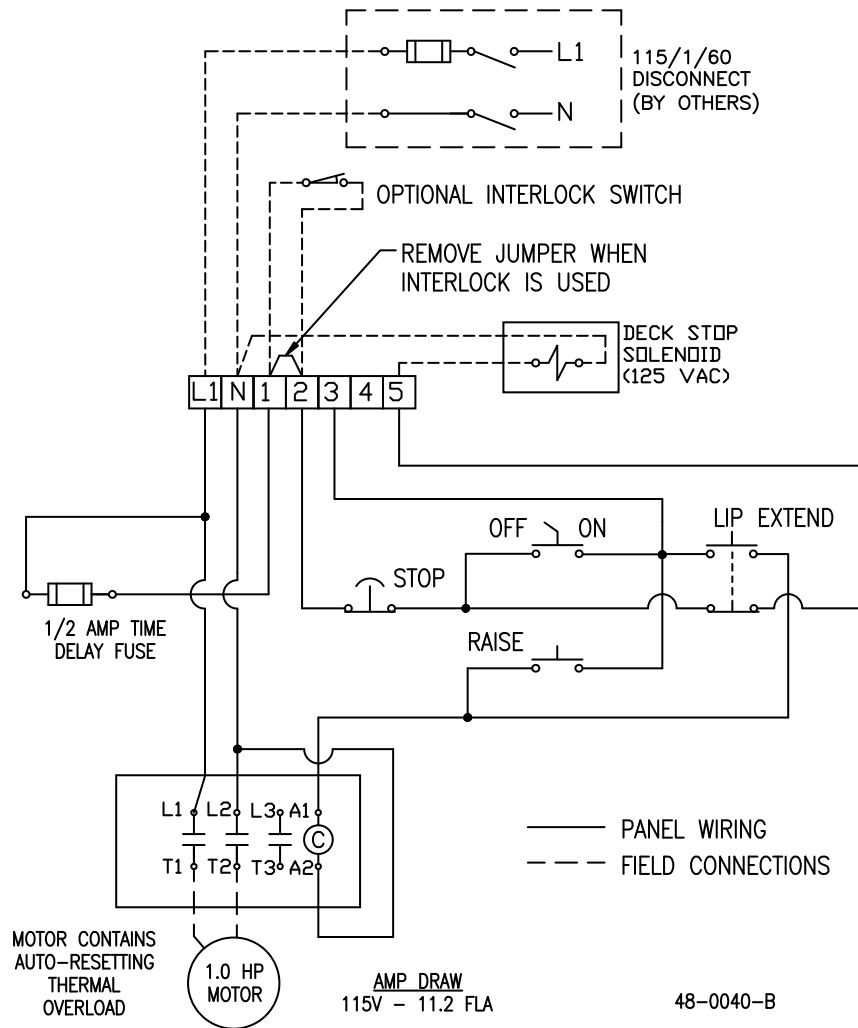

### Single Phase 3 Button 220v - Starter, Lip Out and Emergency Stop

48-0014-B

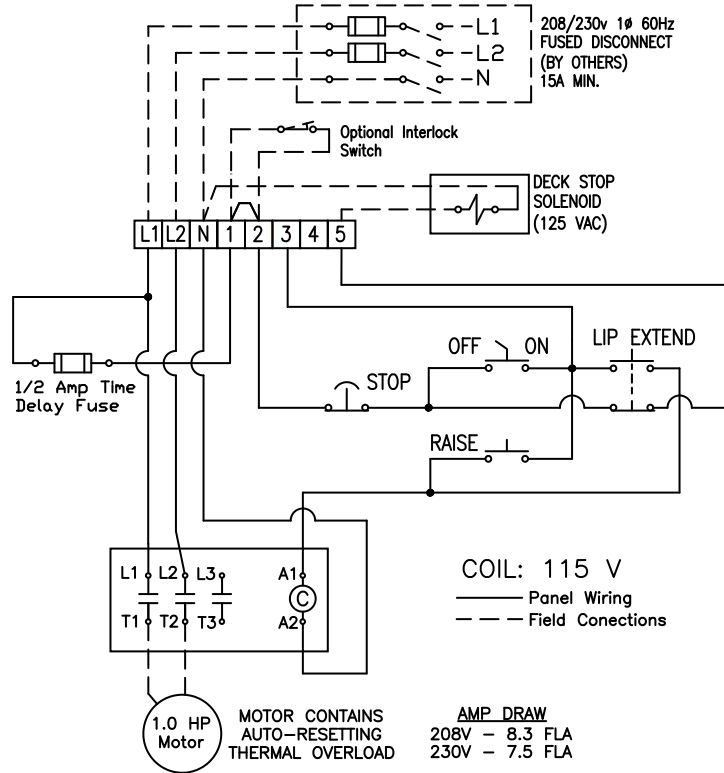

### 3 Phase 3 Button 208v-575v - Starter, Lip Out and Emergency Stop

48-0022-C

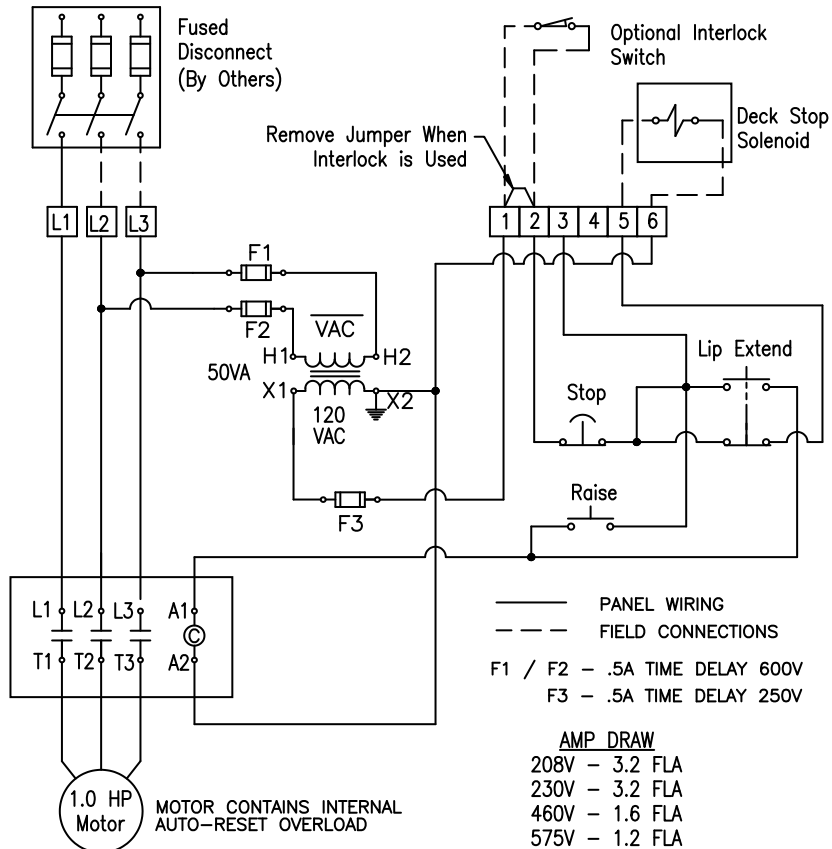

### Single Phase 4 Button 115v - Starter, Lip Out, Emergency Stop and Auto Return

48-0059-B

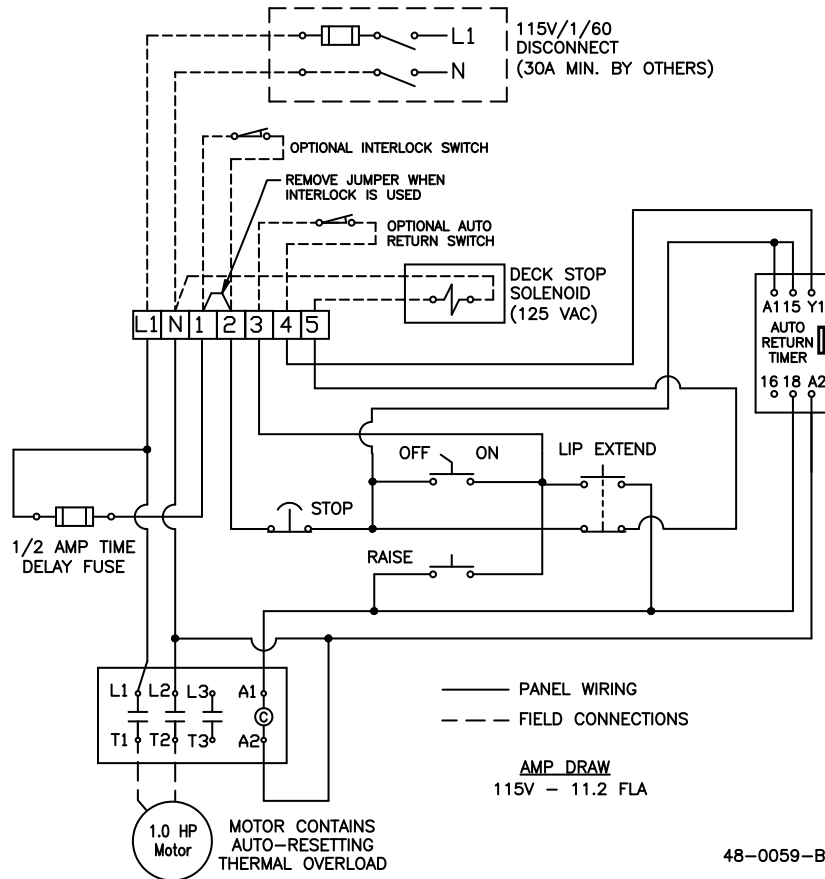

### Single Phase 4 Button 220v - Starter, Lip Out, Emergency Stop and Auto Return

48-0004-E

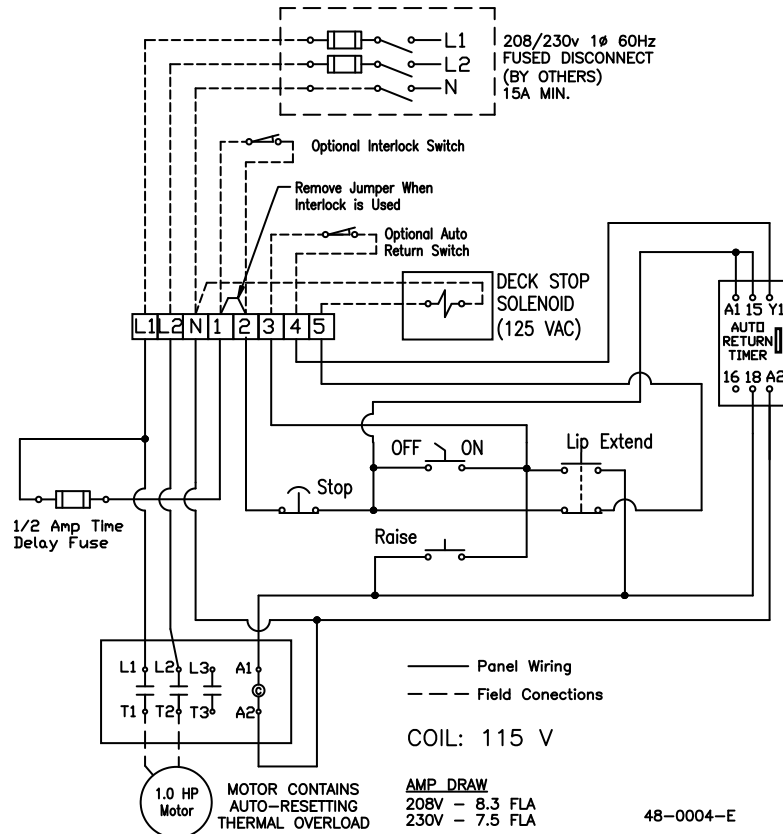

### 3 Phase 4 Button 208v-575v - Starter, Lip Out, Emergency Stop and Auto Return

48-0019-D

