



Constructor AIRDOCK™ Series
Air Powered Dock Leveler
Model "CA"
25,000 to 45,000 lbs. Capacity

Operation and Maintenance Manual

This manual applies to dock levelers manufactured on or after
April 2020 with Serial Numbers 49439 and greater.

P/N: 49-0229-B

NORDOCK INC.

Website: nordockinc.com ~ Email: sales@nordockinc.com ~ Toll free: 866-885-4276
Nordock Inc. reserves the right to make changes to specifications without notice or obligation. Nordock products are covered by
U.S. Patents: 8,132,280; 7,603,733; D579,754; 7,384,229; 7,162,762; 7,013,519; 6,912,750; 6,834,409 and U.S. and foreign
pending applications.

Preface

PLEASE READ AND UNDERSTAND THIS MANUAL COMPLETELY

This manual gives detailed information and instruction on how to operate and maintain your equipment correctly. Failure to do so could result in personal injury, and/or equipment damage. Please consider this manual a permanent part of the unit and keep it with the dock leveler for reference whenever needed.

If you have any questions about this manual, the dock leveler, its components, or our products and services, please call us at 1-866-885-4276 and we will be happy to assist you. With proper care and maintenance, this dock leveler is designed to work effectively and efficiently for many years to come.

Problems, Errors and Omissions

This manual has been prepared with the utmost care and attention to detail as to ensure accurate parts and service information should the need arise. Nordock Incorporated believes this manual will provide the operators of this unit all the necessary information required to operate and maintain it for many years. If you believe there is an error, if you have a problem following the guidelines, or if there is information that you feel is missing from this manual, please contact us at the above number so we may attend to the issue immediately.

Dock Identification

It is very important that in order to provide the best possible service from Nordock Inc., please include the model, serial number and capacity of the dock leveler whenever you contact us. Below are the model and serial number decals that will be found on the left side frame rail (standing on the dock, facing the lip). Please fill in the information from the decal on the dock leveler to this area. This will greatly reduce the possibility of improper parts being shipped to you.

NORDOCK[®]

DESCRIPTION: _____

SERIAL #: _____

866-885-4276 ~ WWW.NORDOCKINC.COM
MADE IN CANADA

Copyright

This manual is copyright to Nordock Incorporated. All information, text, drawings, and technical data contained herein are for reference only. No part of this manual may be copied, altered, or stored on electronic media, and cannot be revealed to others for the purpose of competition.

Table of Contents

Preface	i
Problems, Errors and Omissions	i
Dock Identification	i
Copyright	i
Table of Contents	2
Warranty	3
Safety	4
Operation	4
Maintenance Procedure.....	5
Labels	6
Installation	7
Pit Check	7
Dock Installation	7
Bumper Install.....	12
Operation	13
Standard (Single Pushbutton) Control Panel	13
Below Dock Control (BDC) End Loading (Optional).....	14
Troubleshooting.....	14
Suspected Air Leak.....	14
Blower does not operate when button is pressed	14
Blower operates but Dock Leveler does not raise.....	15
Dock leveler fails to lower	15
Lip fails to extend, lock or retract	15
Unexpected noise	16
Maintenance and Lubrication	17
Acceptable Lubricants and Oils	18
Grease	18
Light Oil.....	18
Chain Lube (Spray Type)	18
Parts and Service Tables	19
Section 1 – Deck and Lip Assembly	20
Section 2 – Lip Extend Assembly	22
Section 3 – Air Blower Motor Assembly.....	23
Section 4 – Air Pan Assembly	24
Section 5 – Lifting Assembly.....	25
Section 6 – Frame Assembly	26
Section 7 – Optional Equipment	26
Section 8 – Control Panels	26
Wiring Diagrams	27

Warranty

Nordock Inc. expressly warrants that MODEL CA AIRDOCK™ dock levelers shall remain free of defects in material and workmanship under normal use for a period of one-year from the date of delivery to the purchaser. The purchaser must maintain and operate the product in accordance with proper procedures. In the event the product proves defective in material or workmanship, Nordock Inc. will either:

1. Replace the product or the defective portion thereof without charge to the purchaser; or,
2. Alter or repair the product on site or elsewhere, as may deem advisable, without charge to the purchaser.

In addition, Nordock guarantees, under specified guidelines, the structural components* for ten years, the front and rear hinges for twenty years and the lift mechanism for five years.

The warranty stated herein is that offered by Nordock Inc. and expressly disclaims all implied warranties including those of merchantability and fitness. This warranty does not cover any failure caused by improper installation, misapplication, overloading, abuse, negligence, or failure to maintain and protect the equipment from vehicle impact. Nordock Inc. or its representative assume no responsibility or liability for any incidental or consequential damages of any kind including loss of use of any equipment, damage or failure resulting from the use of unauthorized replacement parts or equipment modification, or damages resulting from the misuse of the equipment.

Nordock Inc. warranties extend only to the product itself. Nordock Inc. disclaims all liability of any kind arising out of the workmanship, methods and materials used by the installer or premature product wear, product failure, property damage or bodily injury arising from improper installation. These warranties as stated herein are the exclusive remedies for all claims.

* Structural components include the deck, lip and frame welded assemblies. Lift mechanism components include the bag, motor and chains. All structural guarantees are based on the Nordock Application Guide that must be adhered to.

These warranties as stated herein are the exclusive remedies for all claims.



Safety



WARNING

The operators of this unit must read these safety practices before installing, operating or servicing the dock leveler.

FAILURE TO FOLLOW THESE SAFETY PRACTICES MAY RESULT IN BODILY INJURY, PROPERTY DAMAGE OR DEATH.

Read and follow the operating instructions contained in this manual before operating the dock leveler. If you do not understand the instructions, contact your supervisor for an explanation on the safe operation of this unit or call Nordock Inc. at 1-866-885-4276. The following guidelines are to be used in conjunction with all laws, governances and codes in effect where the dock leveler is installed.

Operation

1. Inspect the dock leveler both before the truck arrives, and once it has left to ensure that all parts are undamaged and in good working order. If the dock leveler does not appear to function properly, or if it looks damaged, disconnect the power supply, lock out the control panel and immediately report it to your supervisor and safety representative.
2. Do not attempt to service trailers that are outside the safe operation service range. Service range varies depending on the combination of dock and lip length. Contact Nordock Inc. or an authorized service representative to determine the correct range for this particular dock leveler.
3. Be sure that the tires of the truck are properly chocked, or that the truck is properly locked in place by a functioning restraining device before loading or unloading.
4. Stay clear of the dock leveler when it is in motion.
5. Do not operate the dock leveler with equipment, material, or people on the ramp or lip, and **NEVER USE A FORK TRUCK OR ANY TYPE OF MATERIAL HANDLING EQUIPMENT TO LOWER THE RAMP.**
6. Keep hands and feet clear of hinges at all times. Do not attempt to raise the ramp or lip manually. If the dock leveler fails to operate using the procedures contained in this manual, do not use the dock leveler. Disconnect the power supply, lock out the control panel and immediately report it to your supervisor and safety representative. Contact Nordock Inc. or an authorized service representative for service.
7. Stay clear of the leveler unless the lip is supported by the trailer bed or by both keeper lugs at the front of the dock. **An unsupported leveler can lower rapidly and unexpectedly.**
8. Ensure the dock leveler is clear of all material, equipment, or people before the chocks are removed, or the truck is released from the restraint. After loading or unloading, make sure the dock has been returned to its level, stored position.

If you have any questions, contact your supervisor or your local Nordock Inc. representative.

Maintenance Procedure



WARNING

USE EXTREME CAUTION WHEN INSTALLING THE MAINTENANCE STAND.

ONLY USE THE PIN PROVIDED TO PROPERLY LOCATE THE MAINTENANCE STAND. SUPPORTING THE LEVELER AT ANY OTHER LOCATION CAN RESULT IN SERIOUS BODILY HARM AND EQUIPMENT DAMAGE.

BE SURE THE POWER HAS BEEN DISCONNECTED, THE CONTROL PANEL IS LOCKED OUT AND BOTH LIP AND DECK MAINTENANCE SUPPORTS ARE IN PLACE BEFORE ENTERING THE DOCK LEVELER PIT AREA.

Before operating or maintaining the dock leveler, read and follow the practices in the Safety Section and all warnings contained in this manual. Failure to follow the guidelines in this manual and those in effect in the workplace can result in serious bodily harm and equipment damage.

1. Raise the dock to its highest position.
2. Remove the maintenance stand located at left side of the frame and position the chained end securely onto the 1" round pin as shown below.

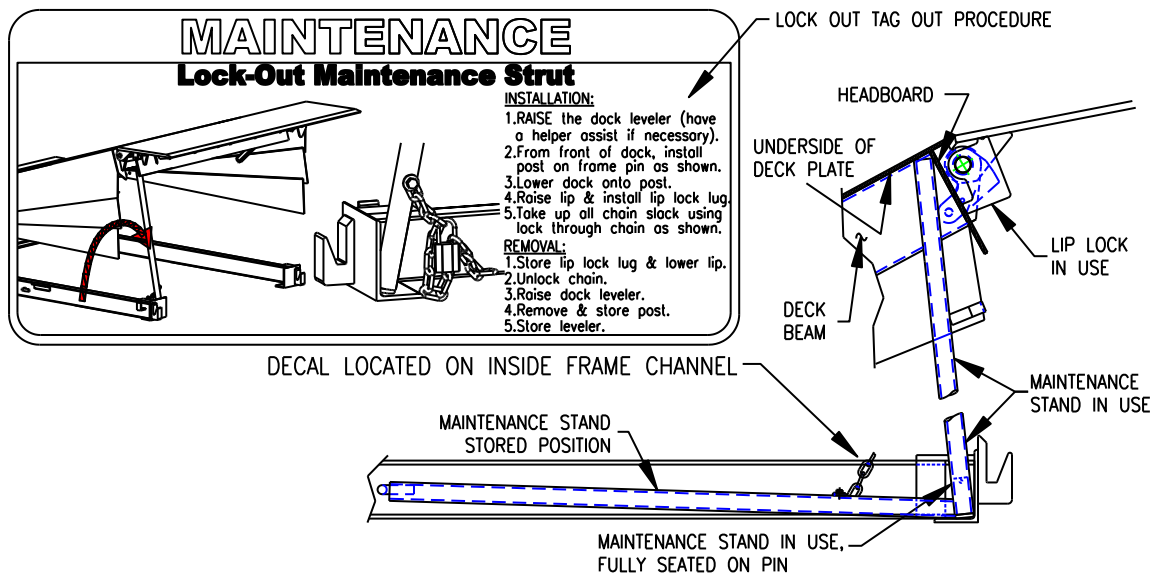

3. Lower the dock onto the stand, making sure the stand supports the deck plate behind the headboard between the deck beams, as shown. DO NOT support the dock under a deck beam or any other part.
4. Raise the lip and use the lip lock (if included) to hold lip in the extended position as shown to right.
5. After completing work on the dock, unlock and lower the lip. Remove the maintenance stand and return to its stored position. Do not stand under the dock after the support has been removed.



Labels

The labels and decals on the dock leveler must be kept in clean, legible condition at all times. The following shows the decals and their placement on the dock leveler. Please check their condition on a daily basis, and replace them immediately if they become unreadable.

CAUTION
 Read and observe these warnings.
 Failure to do so may result in personal injury or property damage.

- o Do not operate or service this equipment without proper training and knowledge.
- o Stand clear of all moving parts.
- o Do not operate this equipment if it appears to be broken or not functioning correctly.
- o Do not conduct maintenance or position yourself beneath the platform or any part of this equipment without the proper support and lockouts in place
- o Contact your supervisor, an authorized Nordock Inc. representative and Nordock Inc. if you have any doubt of the safe operation, maintenance, or service of this equipment.

NORDOCK

DESCRIPTION:

SERIAL #:

866-885-4276 ~ WWW.NORDOCKINC.COM
 MADE IN CANADA

NORDOCK

NORDOCK Phone: 866-885-4276
 www.nordockinc.com

NORDOCK products are covered by one or more of the following U.S. patents: 6,834,409; 6,912,750; 7,013,519; 7,384,229 and pending U.S. and foreign applications.

Trademarks of NORDOCK Inc.
 NORDOCK® AIRDOCK® TRUCK-LOCK® WEARTOUGH™ LOGI-SMART™
 DUAL-DUTY™ HEAVY-METAL™ DURA-GUARD™ MAST-GUIDE™
 PROTECTE ISINGLE-CHAMBER™ HYDRA-FLDA™ AUTO-DECENTLIP™
 AIR-STOP™ FULL-ACTION™ CRASH-GUARD™ DDK-COM™
 COOL-TOUCH™ FALL-STOP™ FDMFRAME™ RAINSHIELD™
 RETRACTAFRAME™ COLDSTORAGE™ SUPER-DUTY™

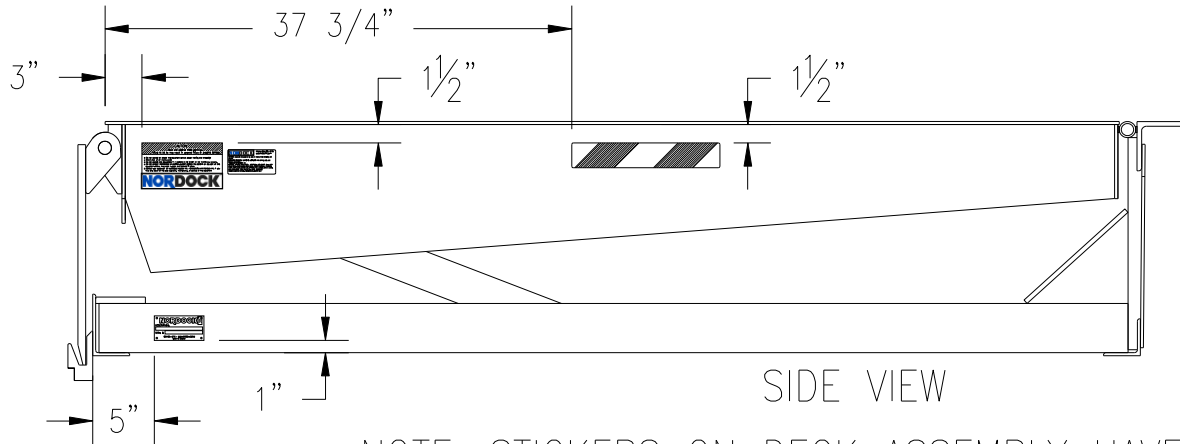
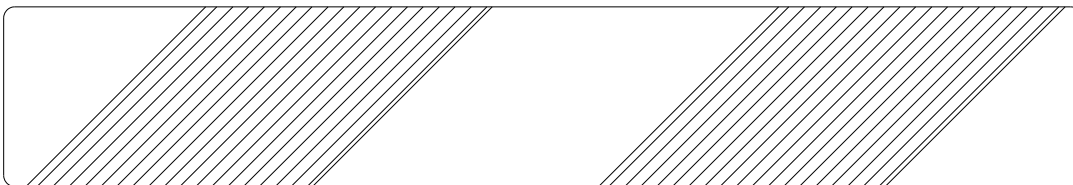

NOTE: STICKERS ON DECK ASSEMBLY HAVE THE SAME PLACEMENT ON BOTH SIDES

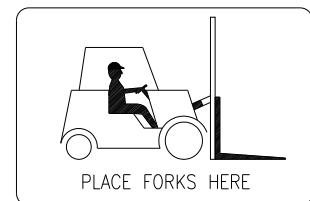
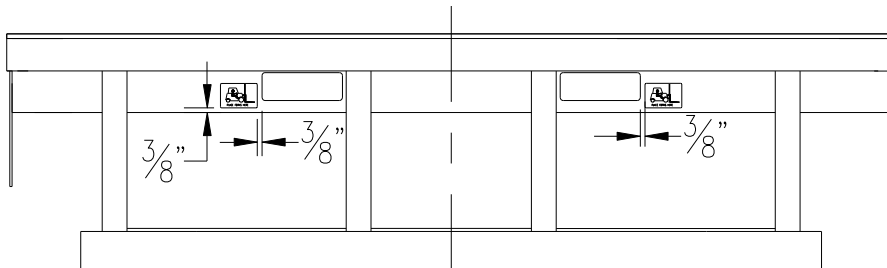

Installation



WARNING

Before operating or maintaining the dock leveler, read and follow the safety practices contained in this manual. Failure to follow the guidelines in this manual and those in effect in the workplace can result in serious bodily harm and equipment damage.

Pit Check

1. Check the entire pit area for proper construction according to the certified pit drawings. Ensure the pit walls are square and plumb. If this is a replacement unit, ensure the steel sections are in good, weldable condition. Check the electrical service and make sure it is the same as the voltage and phase as shown on the wiring diagram in the control panel.
2. Complete any pre-wiring procedures that are required before the dock is placed in the pit. This includes all conduits, wiring boxes, receptacles etc. that are required.
3. One standard 115 VAC receptacle (NEMA 5-15R – supplied by others) is required in the pit to plug in the fan motor. The correct pit wall location for this receptacle is given in the drawing on the next page.
4. Make sure that any conduits and/or junction boxes do not interfere with the rear frame uprights. See the diagram on the following page for proper placement.

Dock Installation

Note: When moving the dock leveler in preparation for installation, it is crucial that the unit be moved only using the fork pockets at the rear of the frame.

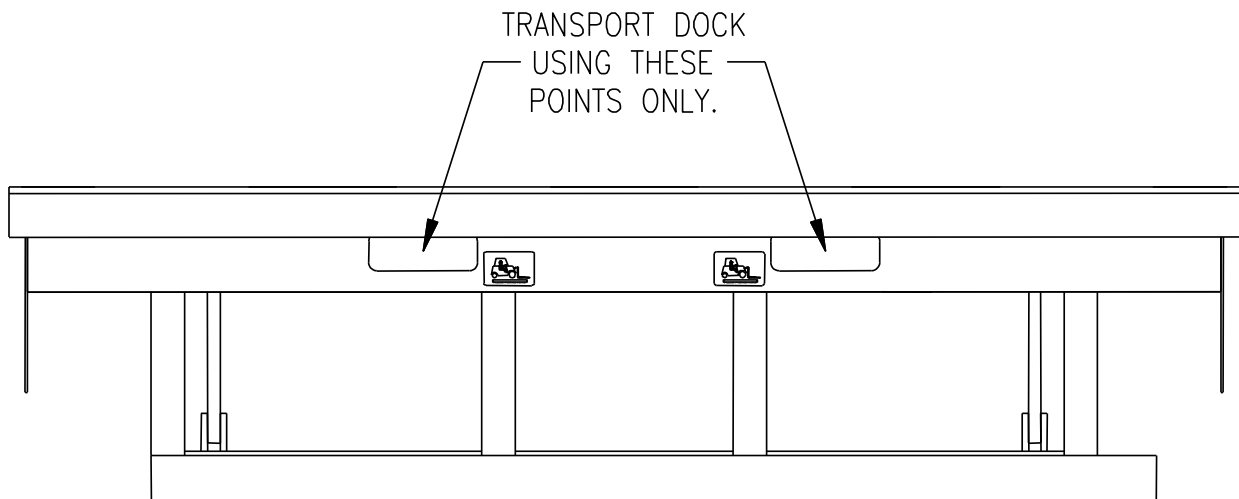

1. The dock leveler has been shipped with the dock bumpers and push-button control station attached to the rear of the frame. These items must be removed before the leveler is placed in the pit.
2. Have the pushbutton station mounted and wired by a qualified electrician. See the electrical diagram inside the control panel or at the end of this manual. Wires shown as dashed lines are field connections.
3. **The rear shims must be measured and welded to the bottom of the rear frame before the dock leveler is placed into the pit.** In order to build up the correct height of shims at each support point, lay a taught string line across the side curb steel approximately 5" in from the rear angle. Stack shims until they are 19" (+1/16" -0") or 23" (+1/16" -0") below the string line. Make sure shim heights are all the same depth from the edge of the pit area. See **Figure 1** for correct placement of shims.
4. Once the correct shim height is achieved for each position, remove the shims from the pit and weld them to their corresponding placement on the leveler frame. For best weld, stagger shims at least 1/4".

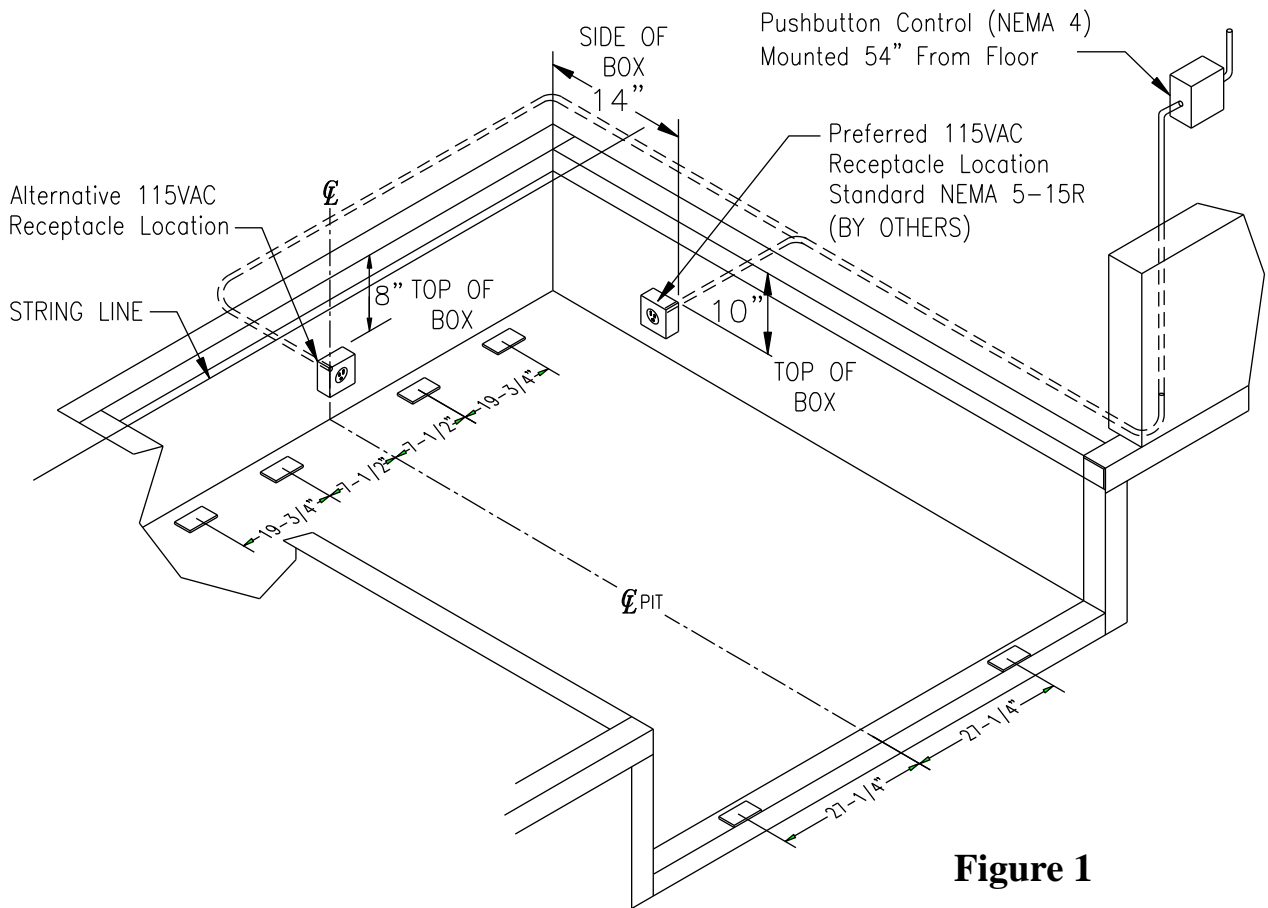

Figure 1

Shims must be placed in the following six areas (refer to **Figure 2**):

- I. Under both frame rails directly behind the lip keeper lugs.
(2 places all 6', 6.5' and 7' 25-50K frames)
- II. Under frame angle at the uprights connecting to the hinge angle.
(4 places all 6', 6.5' and 7' 25-50K frames)

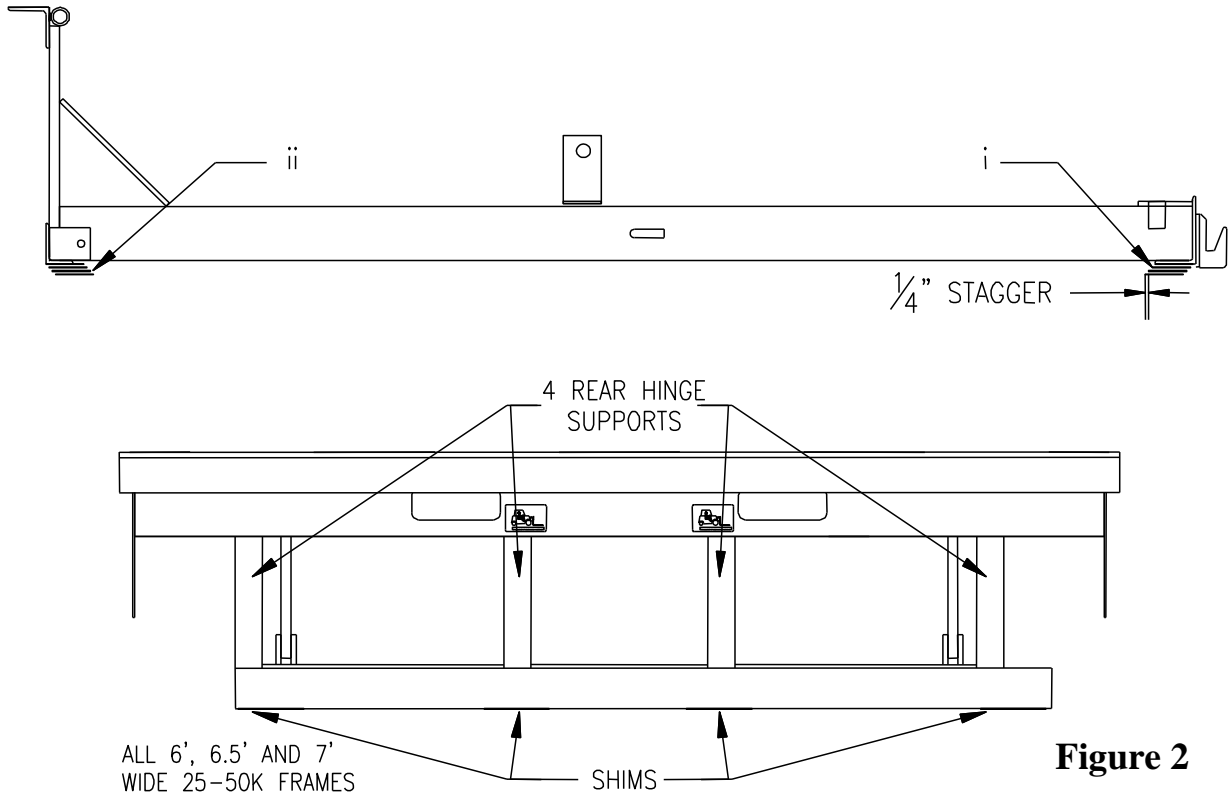

Figure 2

5. Remove any straps holding the motor cord and plug and if required. Temporarily strap it to a rear frame upright so that it can be easily reached for connection to the pit receptacle.
6. Attach lifting chains to the front of dock leveler and a swivel hoisting ring to the rear of the dock leveler in the 3/4"-10 threaded hole.

All chains must be minimum grade 80 and chain hooks have a minimum 1-ton capacity. An endless master link should also be used to assist in the levelling of the dock leveler. Three chains must be used; one hooked at the center of the hinge angle, and two hooked on the front deck plate outside the second set of lip lugs from the sides of the deck. Attach the chains so that the master link is approximately 12" forward of the center of the deck, and centered along the width. See **Figure 3** on the following page.

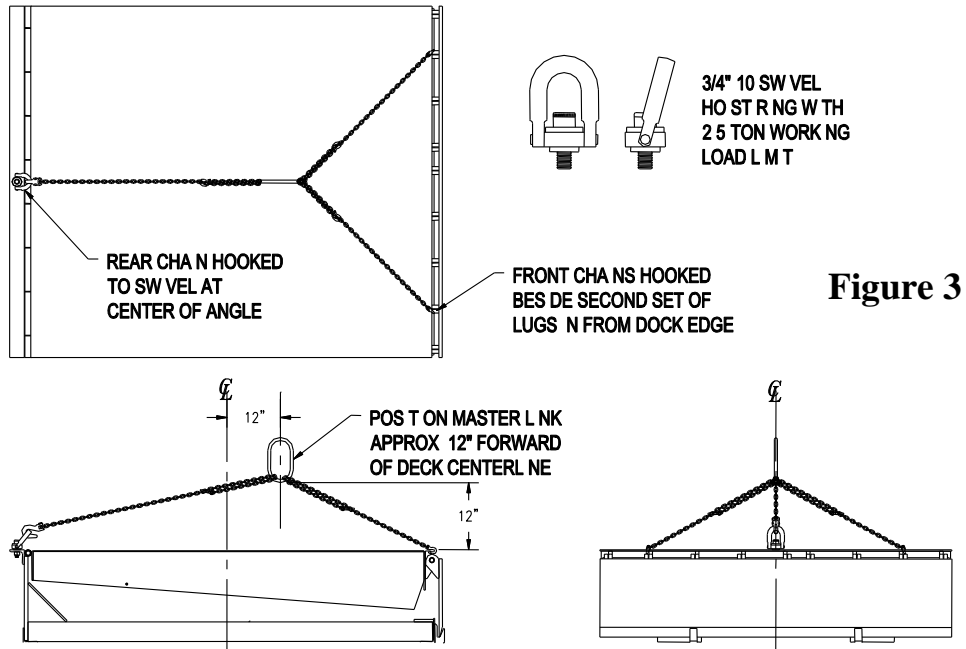

Figure 3

7. Lift the deck approximately 6” and check that it is level. Adjust chains accordingly if required. Do not attempt to install the dock if it is not level. Damage to the unit or personal injury may result.
8. Place dock into pit. Leave room between the dock leveler and the rear pit wall so that the electrical connections can be made.
9. Run the fan cord out the **back of the frame** as seen in **Figure 4**. Plug fan motor power cord into the receptacle at the rear of the pit. If the receptacle is on the side of the pit, run the cord around the back of the frame and up along the outside. **Ensure that, when the dock leveler is pushed into place, the cord does not get crushed and that it is clear of the lifting mechanism.**

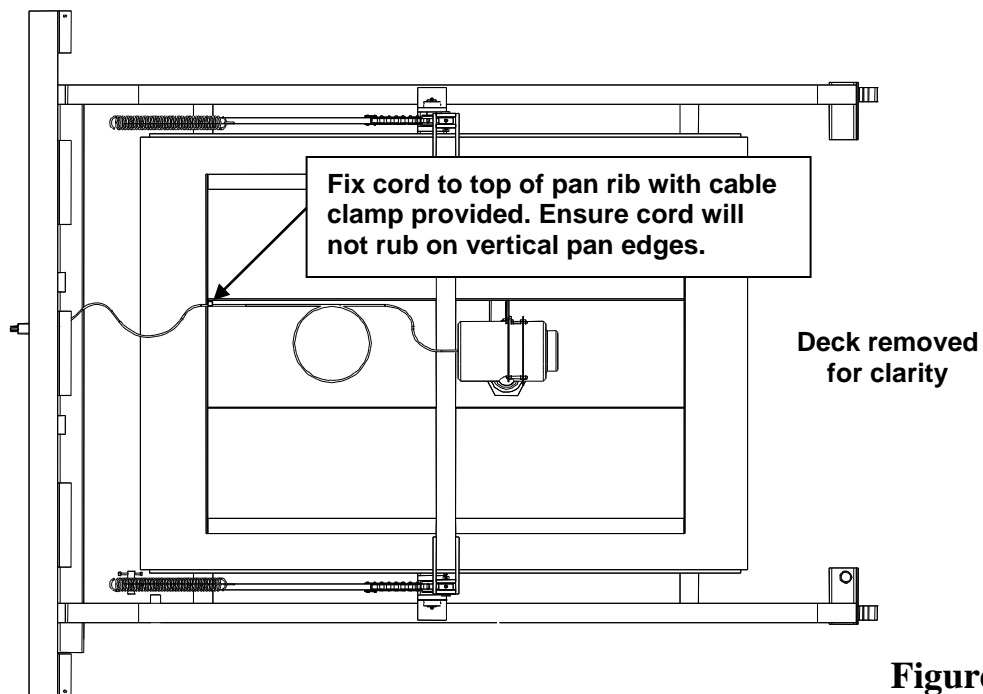

Figure 4

10. Adjust the dock position so that it is centred between the side curb angles and the rear hinge angle is flush vertically and tight to the rear curb angle.
11. Shim under the front of the leveler frame at the locations in **Figure 1** so that the top of the deck is flush with the building floor (-1/16" +0"). Weld the shims together and then to the dock frame and front curb angle.

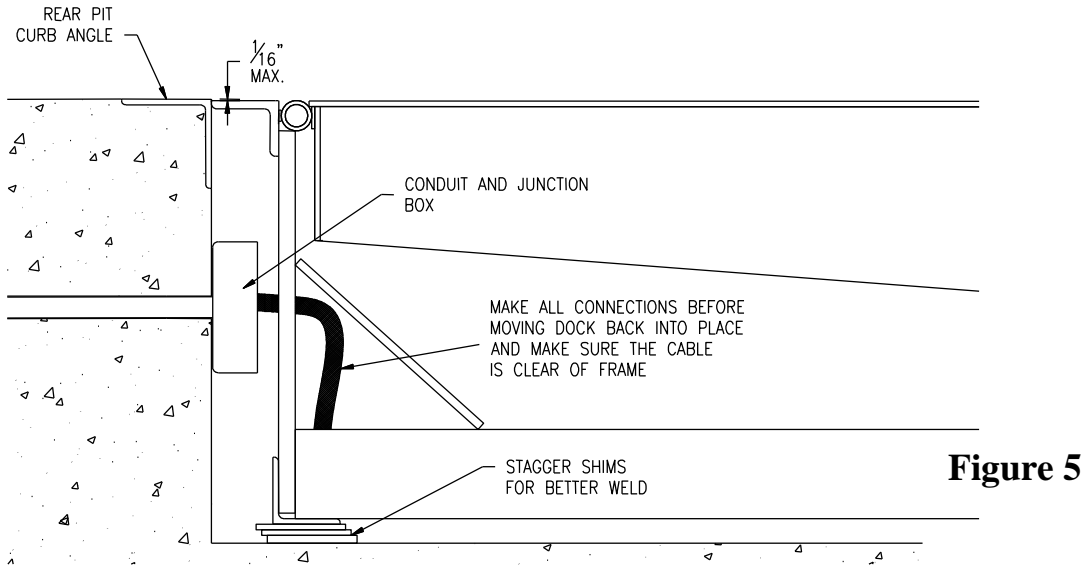

Figure 5

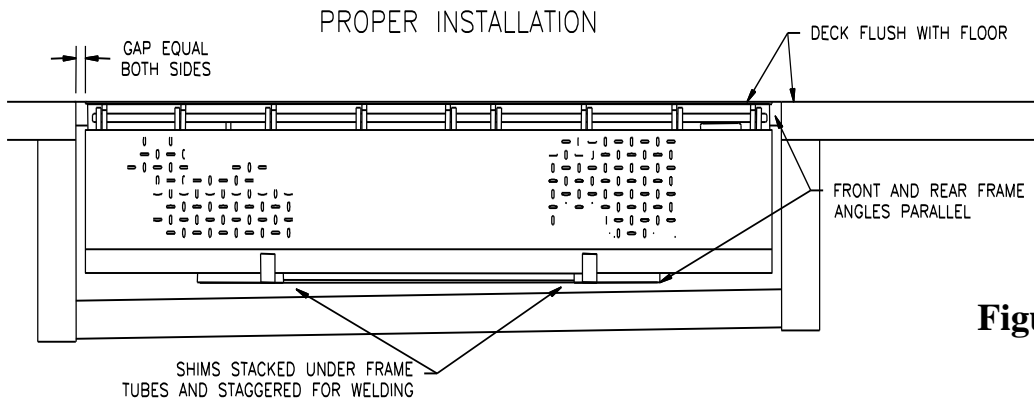

Figure 6

12. Weld the rear hinge angle to the rear and side pit curb angle as shown in **Figure 7**. Ensure the dock leveler power has been disconnected and that the welder is properly grounded to the dock leveler frame.

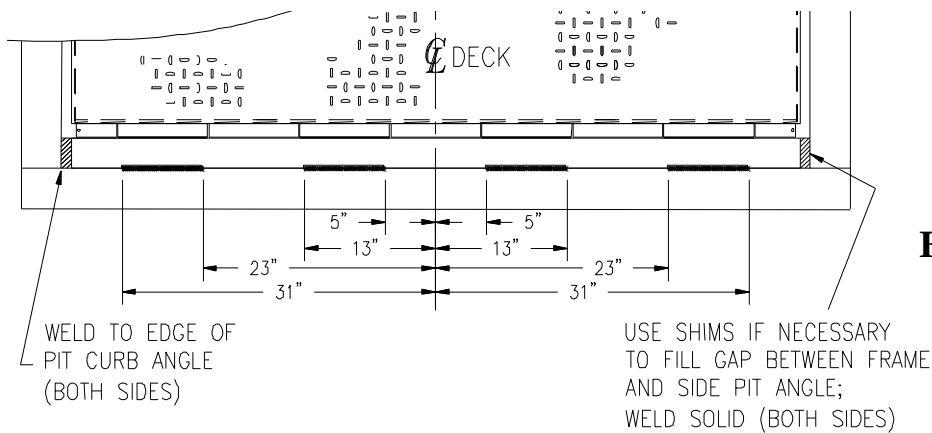

Figure 7

13. Remove all left over debris from the pit and surrounding area and touch-up paint as required (paint supplied by others) to ensure a professional quality fit and finish to the completed installation.

14. The installation is now complete. Give this manual to the customer and make sure arrangements have been made for proper equipment operation training.

Correct installation will ensure consistent, efficient operation for many years to come.

Bumper Install

Bumpers should be installed as follows to prevent damage from trucks backing into the dock leveler.

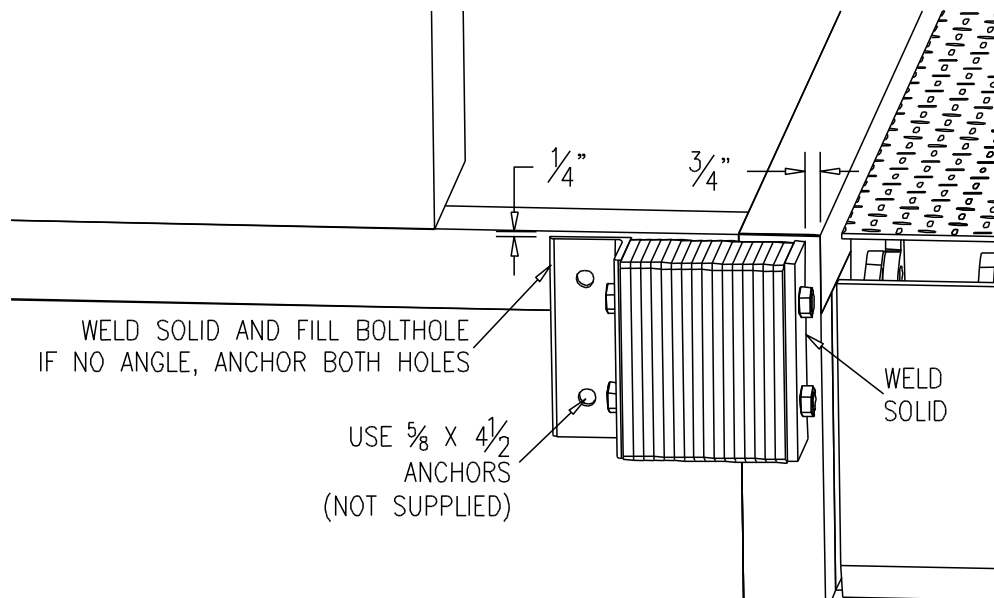

Install bumper so that it is 1/4" below floor level for proper securing, and 3/4" away from the edge of the pit so that the heads of the bolts will clear the lip as it passes the bumper.

Weld the bumper wherever possible to the pit curb angle, and use 5/8" x 4-1/2" wedge anchors (supplied by others) in the angle holes.

Operation



WARNING

Before operating or maintaining the dock leveler, read and follow the safety practices contained in this manual. Failure to follow the guidelines in this manual and those in effect in the workplace can result in serious bodily harm and equipment damage.

Note: If the truck to be serviced is further below dock then the effective dock leveler service range, please see the additional instructions for Below Dock Control.

Standard (Single Pushbutton) Control Panel

1. Open the door and wait until the truck is in position against the dock bumpers.
2. Tell the truck driver **“Your truck must stay at the dock”**.
3. Confirm placement of wheel chock or vehicle restraint.
4. Open overhead door fully.
5. Remove “end load” with the ramp in the stored position if there is not enough room at the rear of the trailer to fit the dock leveler lip.
6. To extend the dock leveler lip into the truck, press and hold the control station button until the deck reaches its maximum height. Release the button and the lip will extend as the deck lowers.

NEVER STAND OR DRIVE ON MOVING RAMP.

7. Proceed with loading or unloading.
8. To return the dock leveler to the stored position when loading or unloading is complete, or to load end loads:
 - a. Press and hold the control station button to raise the dock. Release the button once the lip retracts clear of the truck bed. **The dock will now lower to the stored position.**
 - b. Check that the dock is even with floor level and that the lip is properly stored in the lip keepers. See Figure 4.
9. Confirm removal of wheel chock or vehicle restraint.
10. Tell truck driver **“Your truck may now leave the dock”**.

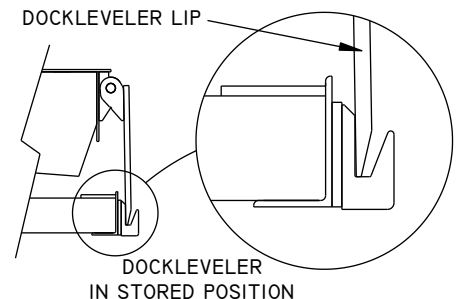
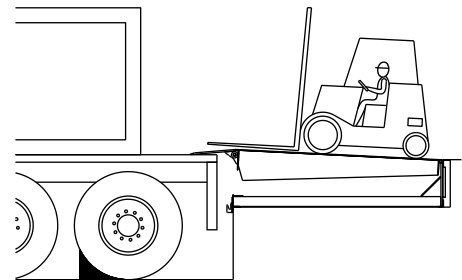
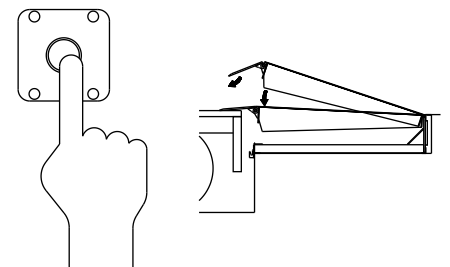
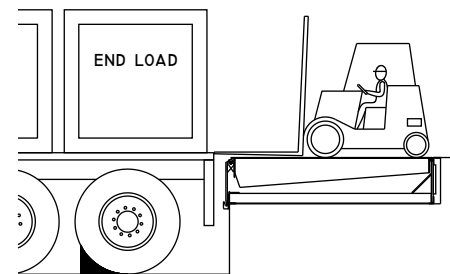
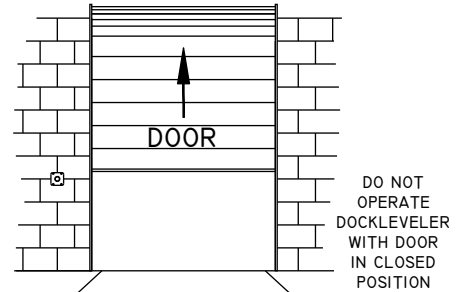

Below Dock Control (BDC) End Loading (Optional)

If end loading is required below dock level, the ramp must be lowered without fully extending the lip. Substitute the following steps in for step 5 of the previous list.

1. Press the “RAISE” button until the ramp reaches a minimum of 4” above the floor. **RELEASE THE BUTTON BEFORE THE RAMP REACHES ITS FULLY RAISED POSITION.**
2. Release the “RAISE” button, pull and hold the BDC chain located in the pocket at the end of the deck as the leveler lowers below level and rest on the frame stops. Do not walk or drive on the dock until it has completely stopped lowering. Release the BDC chain.
3. Load or unload the item to make clearance for lip extension.

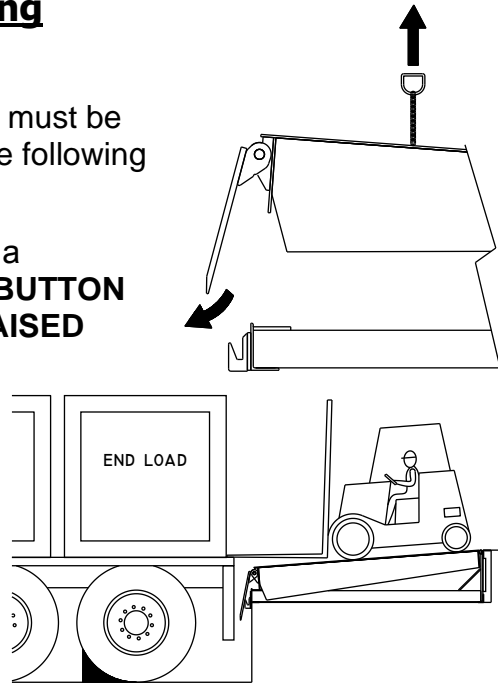

Troubleshooting



WARNING

Before operating or maintaining the dock leveler, read and follow the safety practices contained in this manual. Failure to follow the guidelines in this manual and those in effect in the workplace can result in serious bodily harm and equipment damage.

Note: The following section should be used as a reference guide only. **Only** qualified personnel should perform any adjustments or repairs. Contact Nordock Inc. or your local Nordock representative for service.

Suspected Air Leak

Various malfunctions may be caused by a leak in the airbag lifting system.

- Exceptionally slow lifting speed
- Insufficient lifting power available to fully raise deck and extend lip
- Dock leveler fails to lift while blower motor operates

IF AN AIR LEAK IS SUSPECTED, A FORK TRUCK OR OTHER SIMILAR AUXILIARY MEANS MUST BE USED TO RAISE THE DOCK IN ORDER TO INSTALL THE MAINTENANCE STAND.

Blower does not operate when button is pressed

1. Check that the main power source is turned on.
2. Check that all installation connections are made.
3. Ensure motor voltage matches the incoming service.
4. Ensure pushbutton is functioning.

Blower operates but Dock Leveler does not raise

1. Check motor rotation.
2. Make sure dock leveler is not loaded.
3. Check airbag and pump connection, ensuring there are no leaks.
4. Check for any damaged or broken components.

Dock leveler fails to lower



WARNING

DO NOT ENTER THE AREA UNDER THE DOCK LEVELER IF IT FAILS TO LOWER

1. Check that there are no obstructions beneath the dock.
2. Check that the lip extension mechanism is not jammed in the extended position.
3. Check that there are no bent or broken components.

Note: DO NOT FORCE THE DOCK LEVELER DOWN BY ANY MEANS FOR ANY REASON.



WARNING

DO NOT ENTER THE AREA UNDER THE DOCK LEVELER OR LIP IF THE LIP FAILS TO EXTEND OR FAILS TO UNLOCK.

Lip fails to extend, lock or retract

1. For the lip to extend, the deck must be raised until it hits the stop on the frame **before** the “RAISE” button is released.
If the deck does not reach full elevation, the lip mechanism will not engage and the lip will not extend.
 - i. Check that there is not an air leak around the blower fittings, or a hole in the airbag.
 - ii. Check that there is not an obstruction to the blower air inlet filter.
 - iii. Check that there is not something mechanical obstructing the deck or airpan movement.
2. Once the deck has reached its full elevation the lip mechanism will engage and the “RAISE” button should be released.
If the lip does not extend as the deck lowers:
 - i. Check that the roller in the front lip pushbar turns freely on the axle and that the axle turns freely in the brackets.
 - ii. Check that the rear pushbar fork notches are square, sharp and parallel with each another.
 - iii. With the deck fully raised, check that there is enough tension on the rear pushbar by the spring to hold the roller against the roller block when the deck begins to lower. (Note: The spring becomes slack after the lip begins to extend.)
3. As the dock lowers the lip will extend and lock in position.
If the lip falls back in and/or fails to lock:
 - i. Check items **i & ii** from **step 2**.
 - ii. Check that the front of the roller block is square to the deck and free of burrs and debris.
 - iii. Check that the kick-out lever block rest flat against the deck.

4. When the roller has slipped in front of the roller block, the lip is locked in the extended position.

The lip mechanism will release once a truck bed has supported the lip or once the deck has fully lowered and the frame has activated the kick-out lever. If the lip fails to release:

- i. Check that the front pushbar pivots freely in the brackets on the lip
- ii. Check that the kick-out bar engages with the landing pad on the frame

Unexpected noise

A certain amount of blower noise, mechanical creaking and airbag stretching is to be expected of this machine. Proper lubrication and maintenance inspection will ensure many years of efficient operation. If airbag noise (popping sound caused by the vinyl against the pan surfaces) is louder than expected, check bag for dirt and moisture and clean as necessary.

Maintenance and Lubrication

 **WARNING**

Before operating or maintaining the dock leveler, read and follow the safety practices contained in this manual. Failure to follow the guidelines in this manual and those in effect in the workplace can result in serious bodily harm and equipment damage.

Note: Use only the lubricant grades specified in this manual. Failure to use the materials listed may lead to premature failure, and will void any warranty claims for the dock leveler.

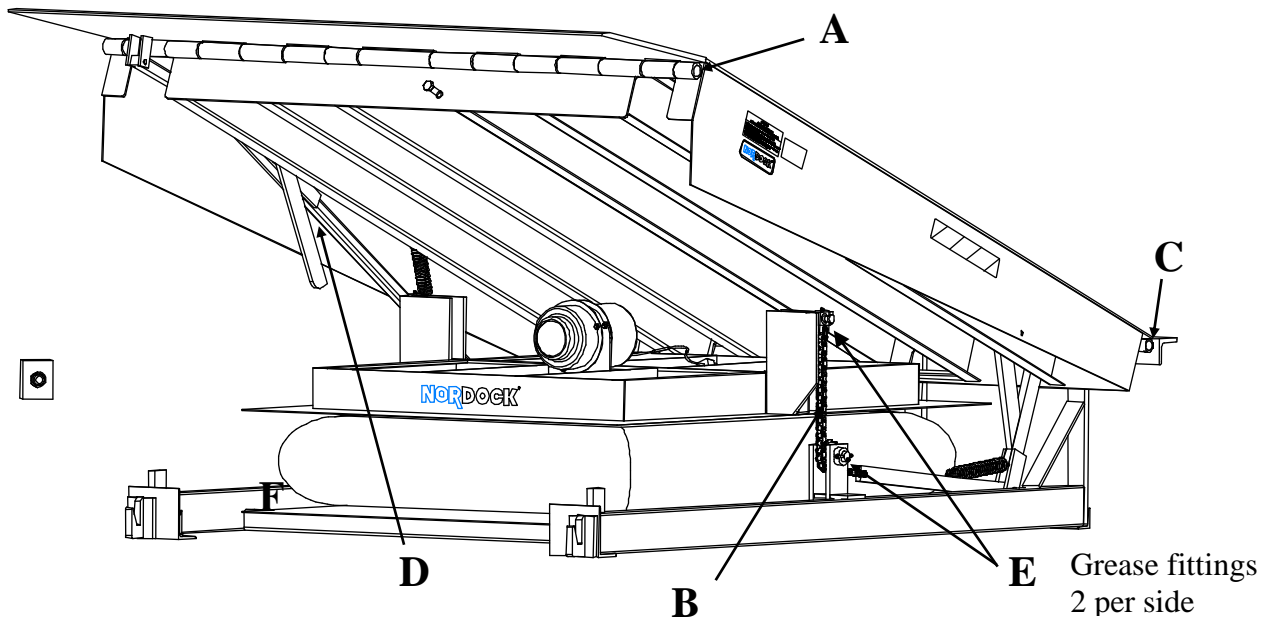

Item	Lubrication	Adjustment	Cleaning
- A - Lip Hinge	Every 90 days Using light oil	None	Remove debris as required
- B - Chain	Every 90 days Using chain lube	None	Remove debris as required
- C - Rear Hinge	Every 90 Days Using light oil	None	Remove debris as required
- D - Lip Extend Mechanism	Every 90 Days Using light oil	None	Remove debris as required
-E- Bearing	Every 90 Days Using Grease	None	Remove debris as required
-F - Pit Area	None	None	Every 90 days or as required to remove debris

Acceptable Lubricants and Oils

Grease

Grease used for hinges must meet a minimum EP-2 grade.

E.G.: CHEVRON DURA-LITH EP-2

Light Oil

Light oils used should have good penetration and adhesion qualities.

Chain Lube (Spray Type)

Lube used for chain should be a lithium based spray lube.

E.G.: CHAMPION CHAIN LUBE

CASTROL CHAIN LUBE

Parts and Service Tables

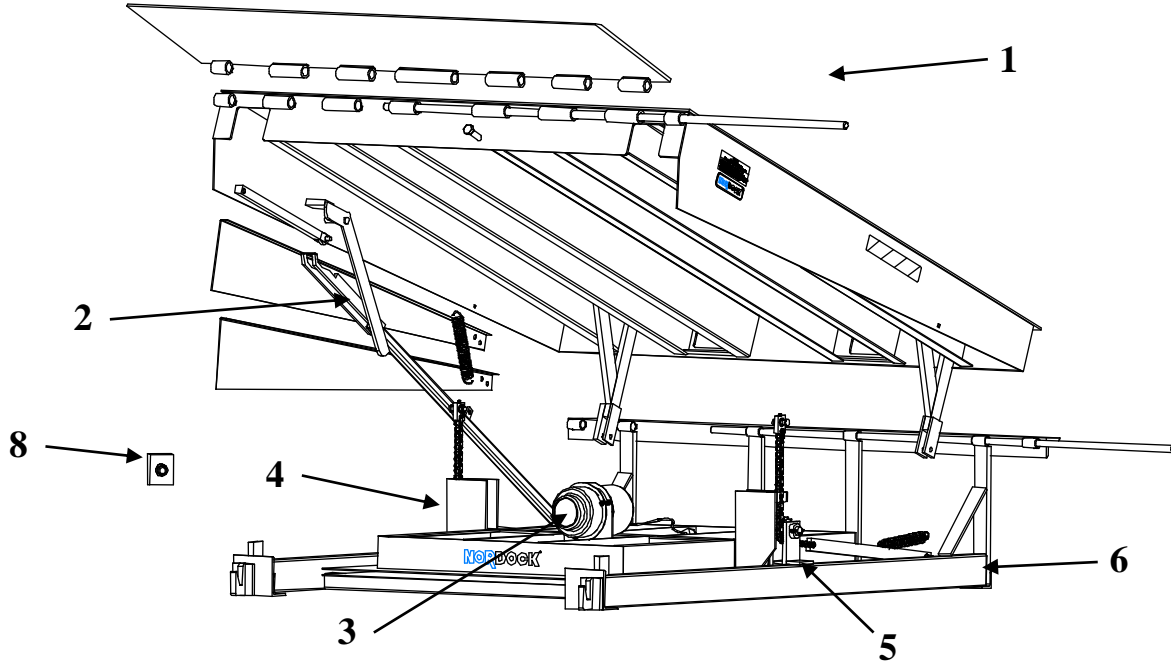

Item Number/ Section	Description
1	Deck and Lip Assembly
2	Lip Extend Assembly
3	Air Blower Motor Assembly
4	Air Pan Assembly
5	Lifting Assembly
6	Frame Assembly
7	Optional Equipment
8	Control Panels

Note: Not all parts and weldments are noted in this manual. Only those that are serviceable and/or replaceable are listed. For additional information on those parts not included in this manual, please contact Nordock Inc. Remember to make note of the model and serial number of the unit for accurate parts and service.

Section 1 – Deck and Lip Assembly

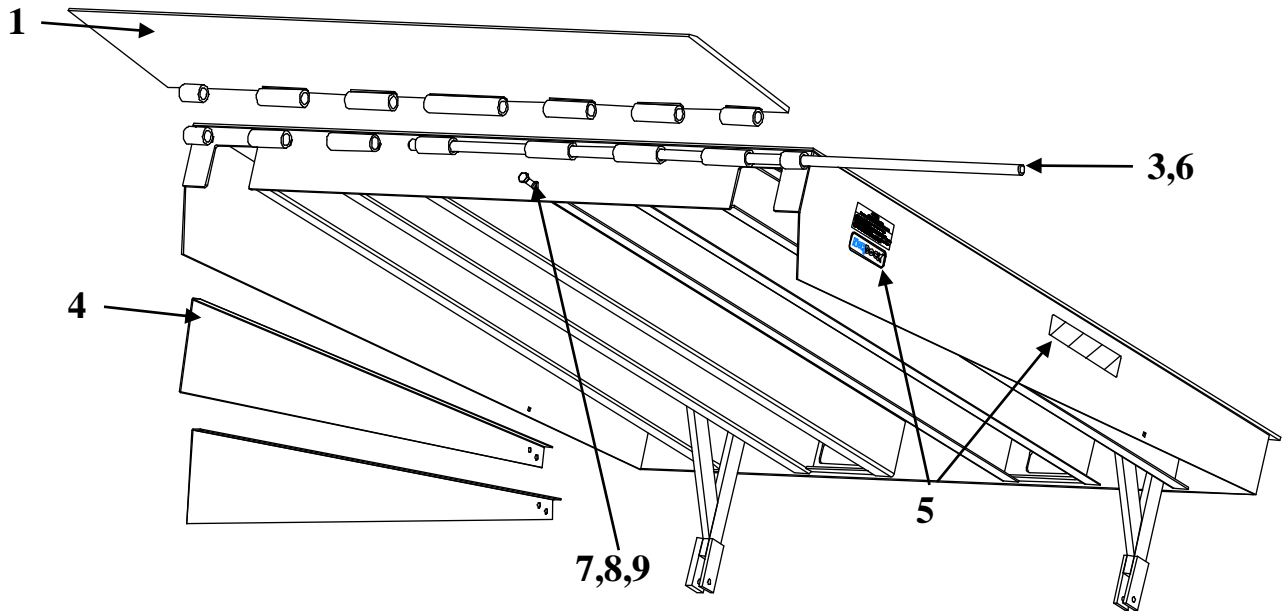

Item	Qty.	Description / Model				P/N	Note
1	1	Lip Weldment	25-30K	6'	16"	42-2339	
					18"	42-2340	
					20"	42-2341	
				7'	16"	42-2357	
					18"	42-2358	
					20"	42-2359	
			7'T	16"	42-2342		
				18"	42-2343		
				20"	42-2356		
			35K	6'	16"	42-2344	
					18"	42-2345	
					20"	42-2346	
7'	16"	42-2347					
	18"	42-2348					
	20"	42-2349					
40-45K	6'	16"	42-2350				
		18"	42-2351				
		20"	42-2352				
	7'	16"	42-2353				
		18"	42-2354				
		20"	42-2355				
7'T	16"	42-2363					
	18"	42-2364					
	20"	42-2365					
2	1	Lip Safety Lock Lug (optional; not shown)				43-0252	
3	1	Hinge Rod	6'	Wide Docks	43-0148		
			7'	Wide Docks	43-0150		
4	1	Telescoping Side Skirt Kit – 6'				42-0393	
	1	Telescoping Side Skirt Kit – 8'				42-0394	

5	1	Dock Leveler Decal Kit	42-0392	1
6	2	Spring Pin	13-0555	
7	1	Nut	13-0289	
8	1	Lip Stop Bolt	13-0302	
9	1	Lock Washer	13-0657	

1 – For correct decal placement, see safety section.

Section 2 – Lip Extend Assembly

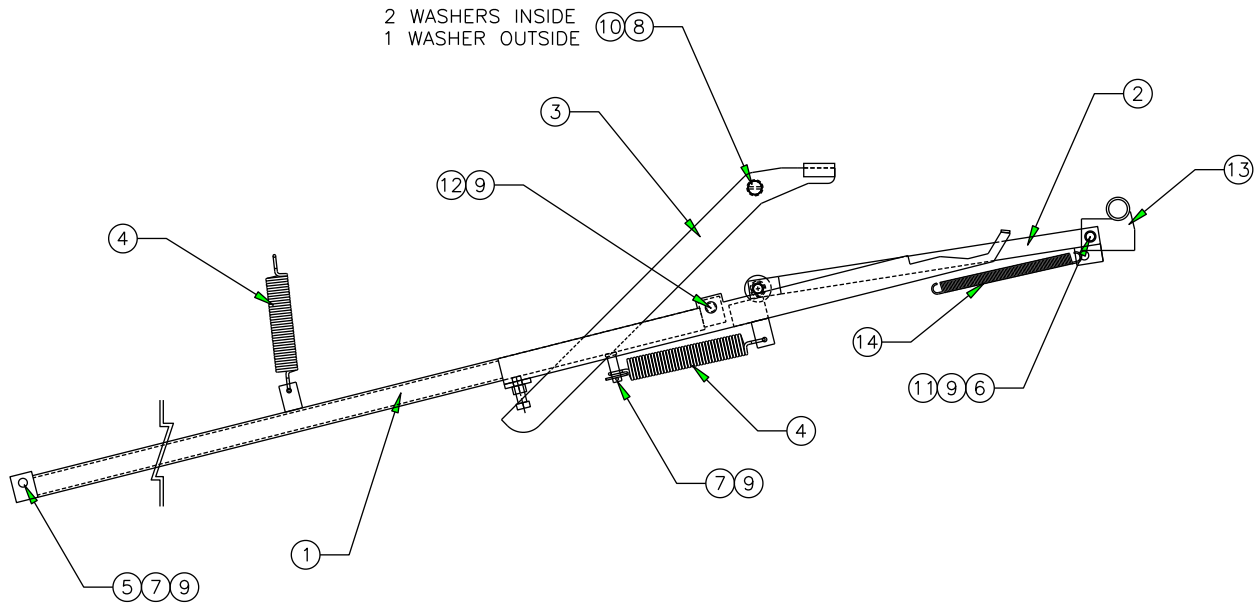

Item	Qty	Description / Model	P/N	Note
1	1	Rear Push-bar	6', 19"F 8', 19"F	42-2217 42-2219
2	1	Front Push-bar Assembly		42-2410
3	1	Kick-out Lever		42-2182
4	2	Spring		13-1955
5	1	Clevis Pin – 1/2" x 2-1/2", Plated		13-1099
6	1	Clevis Pin – 1/2" x 2"		13-0398
7	2	Flat Washer, 1/2", Plated		13-0267
8	3	Flat Washer, 3/4", Plated		13-0649
9	4	Cotter Pin, 1/8" x 1" LG		13-0171
10	1	Cotter Pin, 1/8" x 1-1/2" LG		13-0397
11	1	Sleeve Bushing (included with Item 2)		13-0434
12	1	Clevis pin, 1/2" x 2-1/4", Plated		13-0288
13	1	Lip Cam	25-30K 35-45K	42-2417 42-2411
14	1	Spring, 5/8" OD x 8" long		13-0294
		Complete assembly (includes items 1-12)	6', 19"F 8', 19"F	42-3826 42-3827

Section 3 – Air Blower Motor Assembly

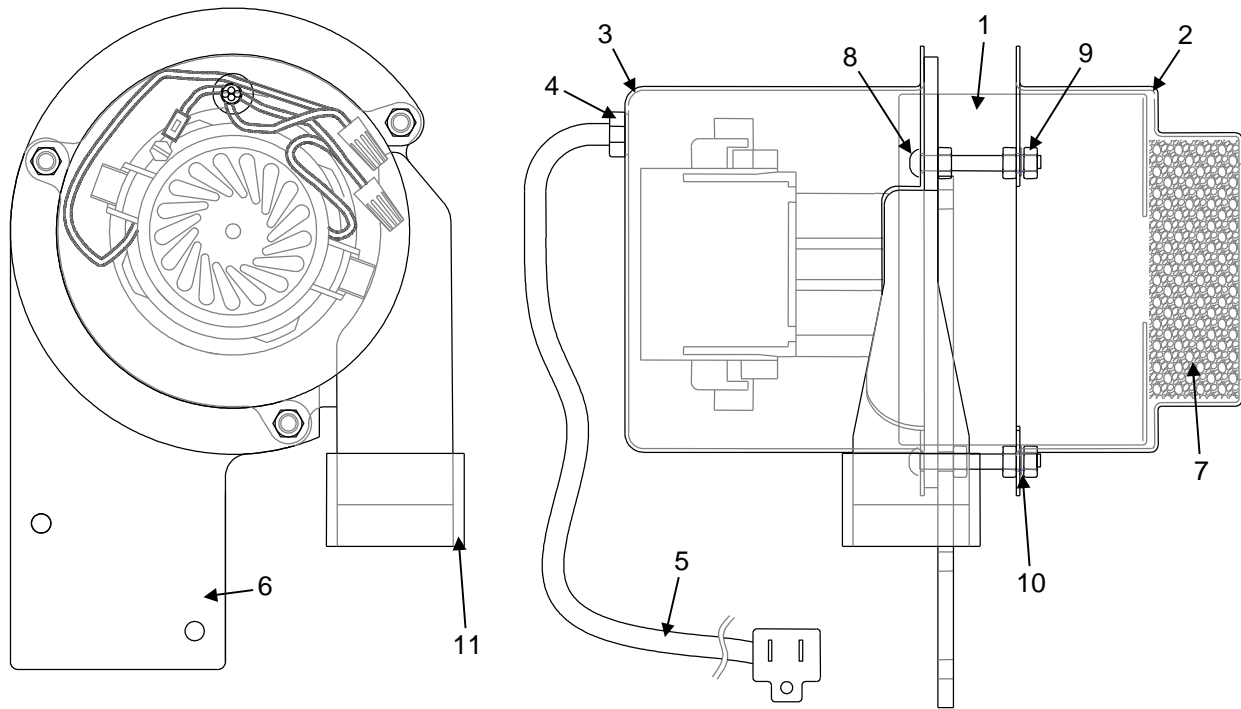

Item	Qty.	Description	P/N	Note
1	1	Blower Motor	13-1847	
2	1	Blower Cover	43-0896	
3	1	Motor Cover	43-0894	
4	1	Strain Relief Grommet	13-1739	
5	1	Power Cord	13-1738	
6	1	Motor Mount Flange	43-0908	
7	1	Intake Filter	43-0923	
8	3	Screw, 1/4" – 20 x 2" Long, Button Head, Plated	13-2018	
9	9	Nut, 1/4" – 20, Plated	13-0334	
10	3	Lock Washer, 1/4", Plated	13-0335	
11	1	ABS Pipe Coupler	13-1796	
		Full Assembly (includes items 1-11)	42-1429	

Section 4 – Air Pan Assembly

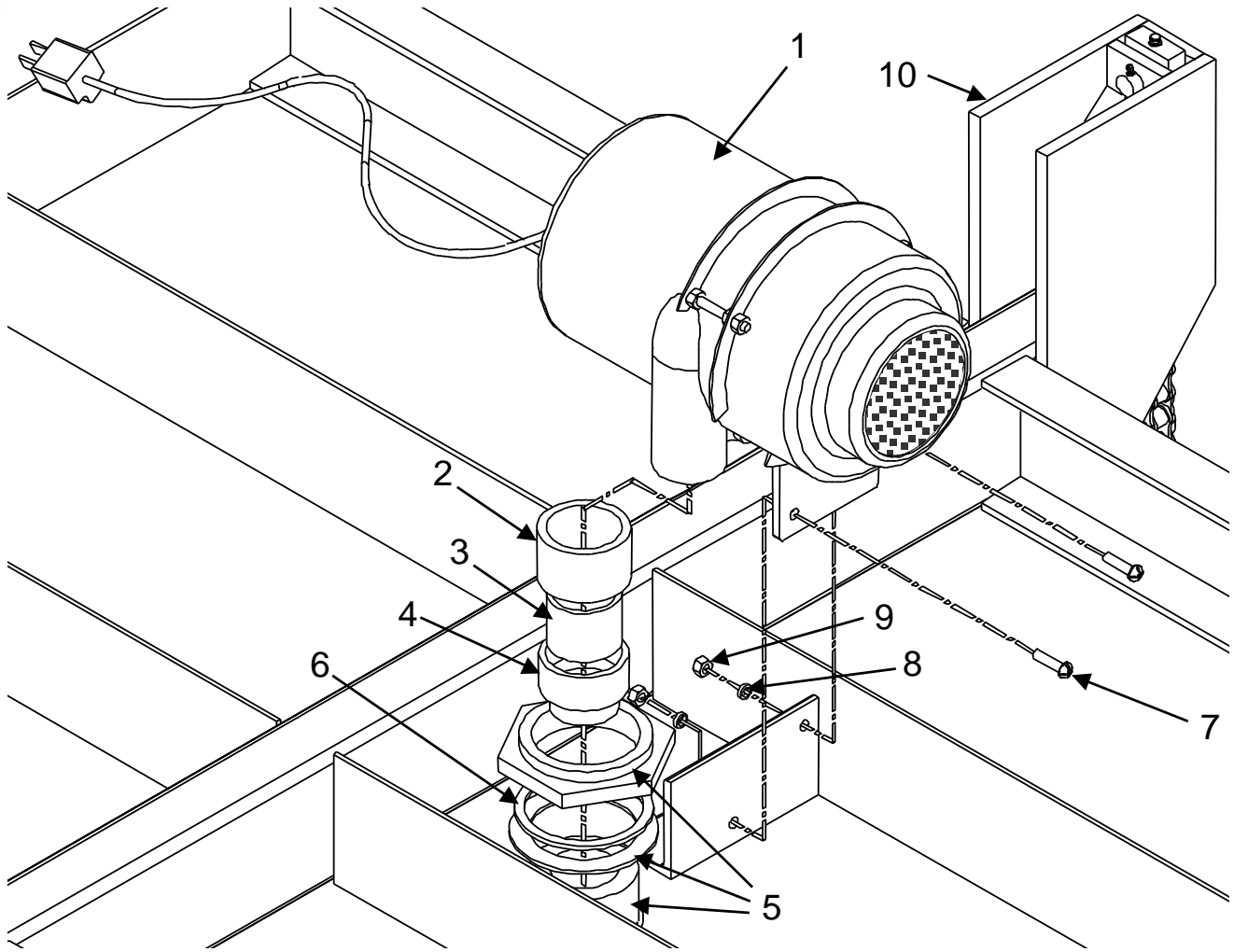

Item	Qty.	Description	P/N	Note
1	1	Complete Blower Motor Assembly	42-1429	
2	1	ABS Pipe Coupler, Ø1-1/2"	13-1796	
3	1	ABS Pipe, Ø1-1/2"	43-0978	
4	1	ABS Adapter, 1-1/2" MNPT x 1-1/2" Female Pipe	13-1797	
5	1	ABS Tank Fitting, 1-1/2" (c/w nut and washer; include with airbag)	13-1775	*
6	1	Spacer Washer	13-1965	
7	2	Bolt, 1/4" – 20, 1" Long, Plated	13-0623	
8	2	Lock Washer, 1/4", Plated	13-0335	
9	2	Nut, 1/4" – 20, Plated	13-0334	
10	1	Top Pan Weldment	6' Dock 8' Dock	42-2237 42-2238
11	N/S	Tank Fitting Wrench	Optional	42-2173

* ABS Tank fitting (item 5) is included with the Airbag (shown in lifting assembly)

* Left hand thread

* Optional tool (item 11) is available to order to ease tightening tank fitting

Section 5 – Lifting Assembly

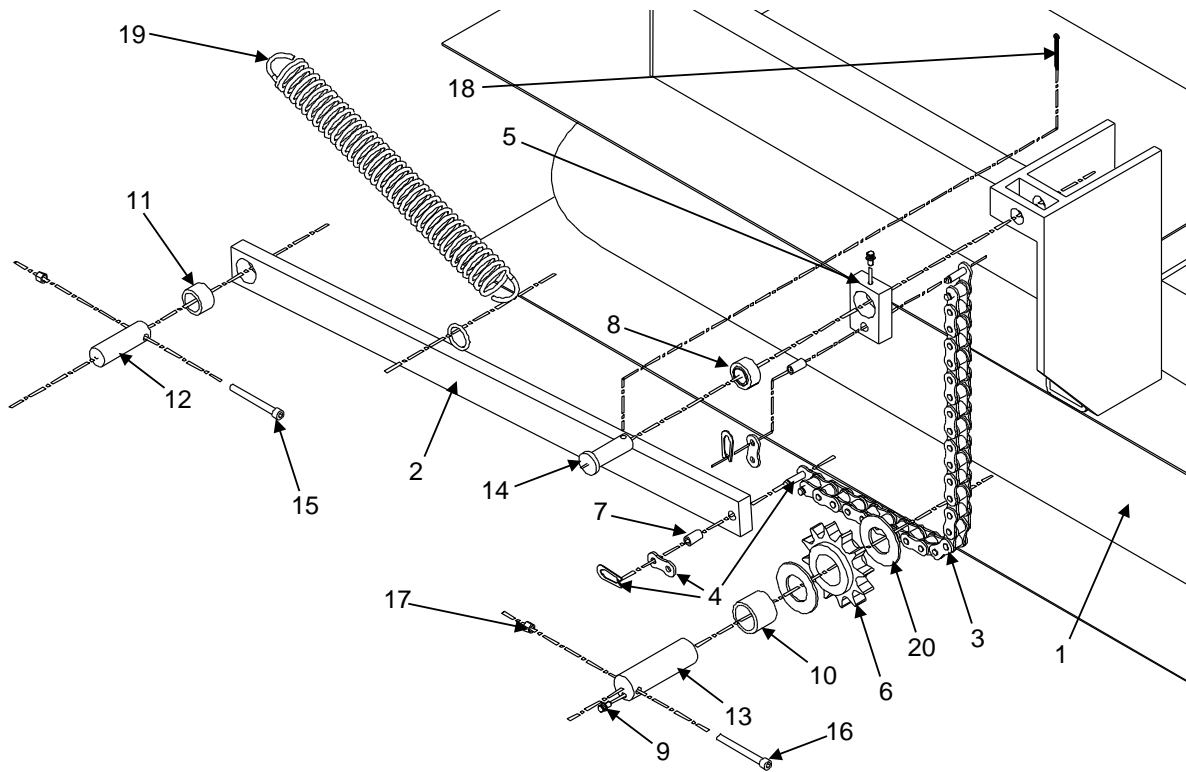

Item	Qty	Description / Model	P/N
1	1	Airbag (includes tank fitting and fasteners)	6' Dock 8' Dock 42-3839 42-3838
2	2	Lower Chain Pull-bar Assembly (includes 7 & 11)	6' Dock 8' Dock 42-2162 42-2151
3	2	Chain	6' Dock 8' Dock 43-0986 43-0987
4	4	Chain Master Link	6' & 8' Dock 13-1741-1
5	2	Upper Chain Pull-bar	6' Dock 8' Dock 43-0866 43-0866
6	2	Sprocket (α - also requires 2 spacers, 43-1064)	6' Dock 8' Dock (25-40K) 8' Dock (45-50K) 43-0882 43-0882 43-0985
7	4	Chain Bushing	43-1100
8	2	Spherical Bearing	13-1848
9	4	Grease Fitting	13-0655
10	2	Sprocket Bearing (13-2103 also includes bearing race 13-2104)	6' Dock 8' Dock (25-40K) 8' Dock (45-50K) 13-1795 13-1795 13-2103
11	2	Lower Pull-bar Bushing	6' & 8' Dock 13-1770
12	2	Lower Pull-bar Pin Assembly (c/w weld-on collar)	6' & 8' Dock 42-2168
13	2	Sprocket Pin Assembly (c/w weld-on collar and grease fitting)	6' & 8' Dock 42-2018
14	2	Clevis Pin	13-0958
15	2	Socket Head Cap Screw, 1/4" – 20, 1-1/2" Long	13-1528
16	2	Socket Head Cap Screw, 1/4" – 20, " 2" Long	13-1850
17	4	Nut, Nylon Locking	13-0270
18	2	Cotter Pin	13-0171
19	2	Tension Spring	13-1955
20	4	Bearing Race Spacer	6' & 8' Dock 43-1064

Section 6 – Frame Assembly

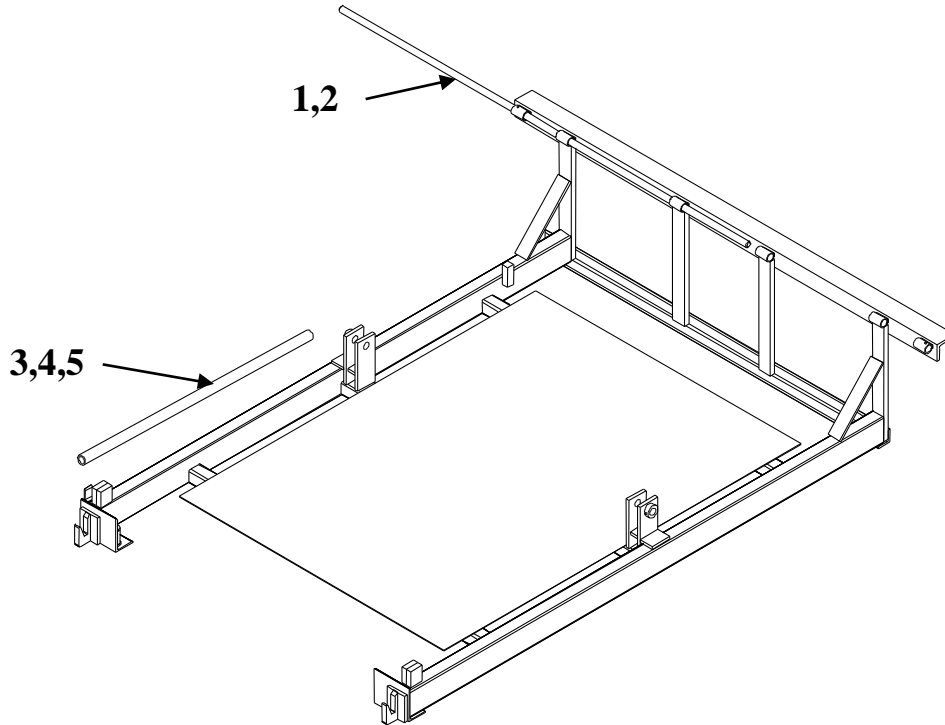

Item	Qty.	Description		P/N 19" Frame	Note
1	1	Hinge Rod	6' Wide Docks 7' Wide Docks	43-0154 43-0156	
2	2	Spring Pin		13-0555	
3	1	Maintenance / Support Stand	Standard Dock (40")	43-0262	
4	1	Fender washer, 1/4"		13-0271	
5	1	Tek-screw, 1/4"-14 x 1"		13-0273	

Section 7 – Optional Equipment

Option	Qty.	Description	P/N	Note
Bumpers	2	Standard Bumpers	61-0001	1
Weather Seals	6'	Brush Seal and Mounting Extrusion Kit	61-0025	
	8'	Brush Seal and Mounting Extrusion Kit	61-0024	
Photo Eye		Photo Eye, Diffuse Reflection	13-2435	
		5 m (16') Cable	13-2436	
		Bracket	13-2437	

1 – For custom bumper sizes and applications, please contact your nearest Nordock representative or call 1-866-885-4276.

Section 8 – Control Panels

Volts Phase	Description	P/N	Note
115/1/60	Standard Panel / Single Pushbutton (NEMA 4)	13-1791	
115/1/60	Single Pushbutton (NEMA 4) with Hinged Lockable Cover	13-2200	
115/1/60	Optional Panel / Single Pushbutton, Interlock (NEMA 4)	48-0065	
115/1/60	Optional Panel / Single Pushbutton, Photo-eye Interlock (NEMA 4)	48-0080	

Wiring Diagrams

The following wiring diagrams may be wired in conjunction with other systems used with the dock leveler. Please consult Nordock Inc. or a qualified electrician before performing any work on the control panel or its components.

Single Phase 1 Button 115V (PN 48-0055)

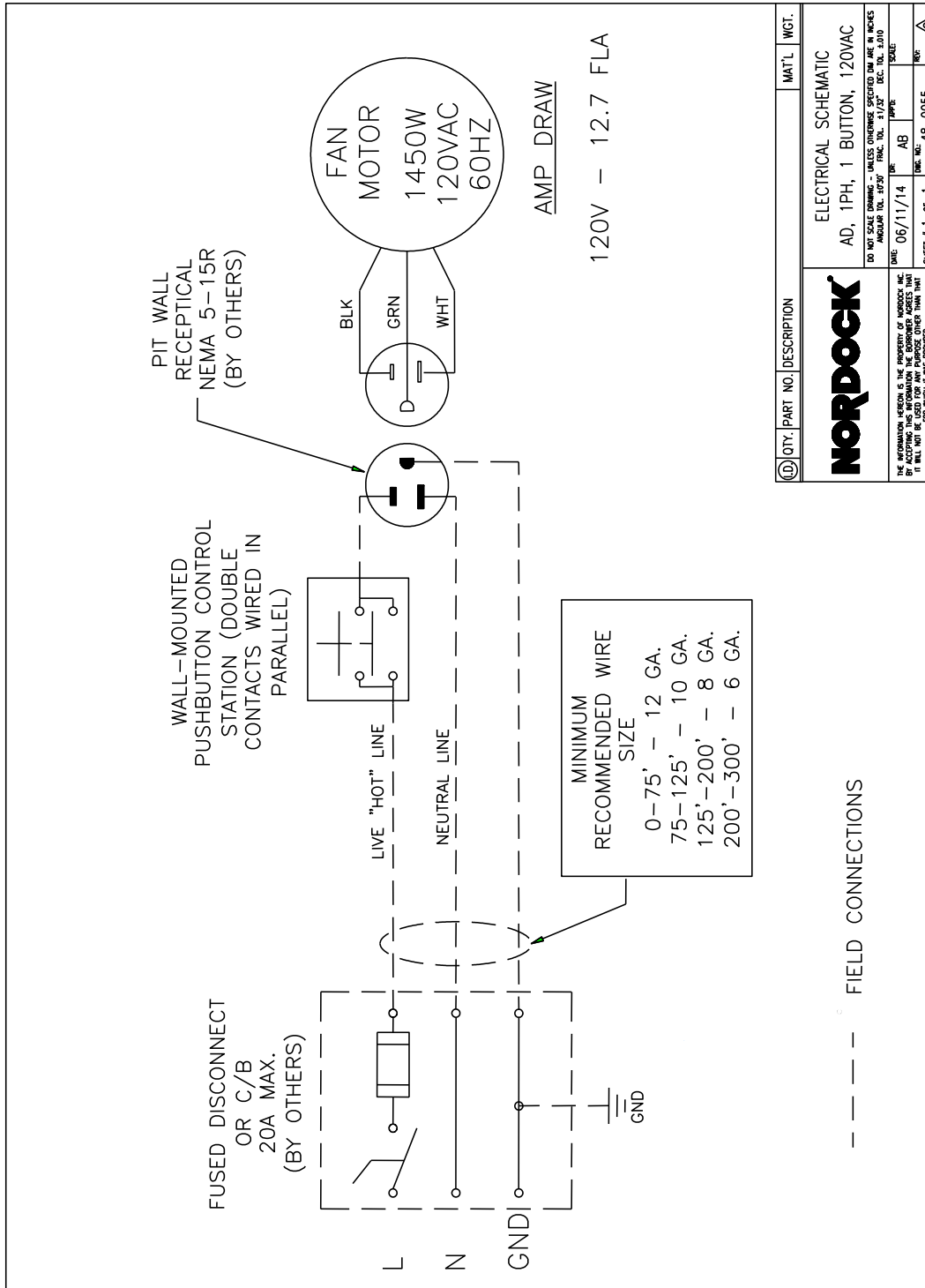

Single Phase 1 Button C/W Interlock 115V (PN 48-0065)

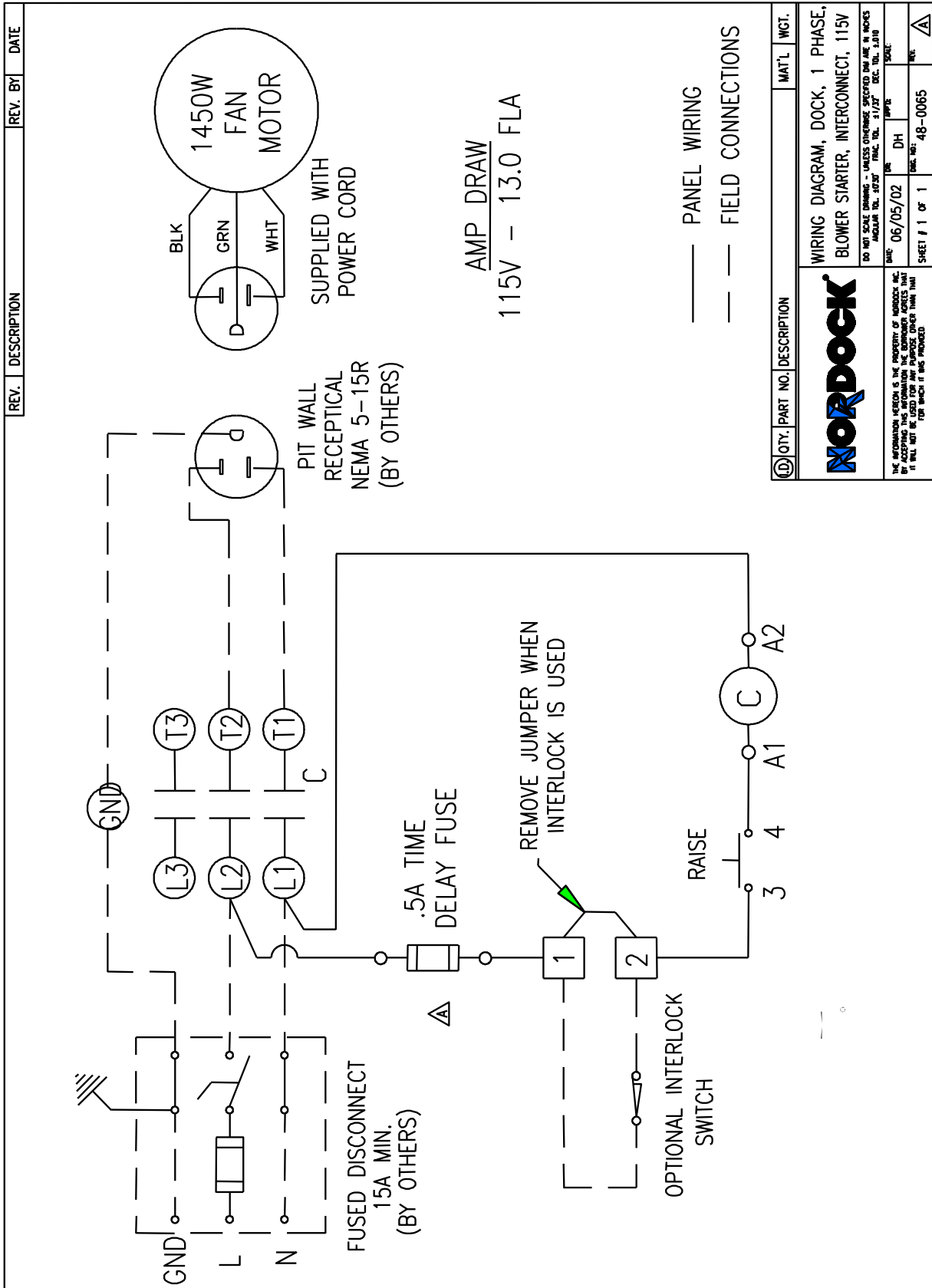

QTY.	PART NO.	DESCRIPTION	MAT'L	WGT.

NORDOCK

WIRING DIAGRAM, DOCK, 1 PHASE,
BLOWER STARTER, INTERCONNECT, 115V

DO NOT SCALE DRAWING - UNLESS OTHERWISE SPECIFIED DIM ARE IN INCHES
ANGULAR DIM. IN DEG. FRACTIONAL DIM. IN DEC. INCHES

DATE: 06/05/02 TIME: 09:45 AM DRAWN BY: JSC/ML

THE INFORMATION HEREON IS THE PROPERTY OF NORDOCK INC. BY ACCEPTING THIS INFORMATION THE BUYER AGREES THAT IT WILL NOT BE REPRODUCED OR TRANSMITTED IN ANY FORM OR BY ANY MEANS WITHOUT THE WRITTEN PERMISSION OF NORDOCK INC.

SHEET # 1 OF 1 TIME: 06:48:00 PN: 48-0065

Single Phase 1 Button C/W Photo-eye Interlock 115V (PN 48-0080)

