

TRUCK-LOCK™ SERIES
ATL-400

Low Profile Automatic
Vehicle Restraint

Owner's Manual

This manual applies to ATL-400 series restraints manufactured after 2013/06/01 with serial numbers 25005 and greater.

P/N: 59-0004 Rev. K

NORDOCK INC.

Website: nordockinc.com ~ Email: sales@nordockinc.com ~ Toll free: 866-885-4276
Nordock Inc. reserves the right to make changes to specifications without notice or obligation. Nordock products may be covered by various U.S. and foreign patents or pending application.

Contents

Contents	0
Preface	1
Problems, Errors and Omissions	1
Restraint Identification	1
Copyright	1
Warranty	2
Safety Practices	3
Labels	4
Installation	5
Mounting Requirements.....	6
Tools Required	6
Installation with Pit Type Levelers.....	7
Installation of Optional Driveway Mounting Plate.....	13
Operating Procedure	15
To Hitch Truck:	15
To Release Truck:	15
Troubleshooting.....	16
Restraint Operating Function Check.....	16
Maintenance Schedule.....	18
Acceptable Lubricants and Oils	19
Hydraulic.....	19
Grease	19
Parts Replacement.....	20
Removing Hook From Track.....	20
Re-Installing Hook Into Track	20
Wiring Diagram.....	21
Parts List.....	22

Preface

PLEASE READ AND UNDERSTAND THIS MANUAL COMPLETELY

This manual gives detailed information and instruction on how to operate and maintain your equipment correctly. Failure to do so could result in personal injury, and/or equipment damage. Please consider this manual a permanent part of the unit and keep it near the restraint for reference whenever needed.

If you have any questions about this manual, the restraint, its components, or our products and services, please call us at 1-866-885-4276 and we will be happy to assist you. With proper care and maintenance, this restraint is designed to work effectively and efficiently for many years to come.

Problems, Errors and Omissions

This manual has been prepared with the utmost care and attention to detail to provide accurate parts and service information should the need arise. Nordock Incorporated believes this manual will provide the operators of this restraint all the necessary information required to operate and maintain it for many years. If you believe there is an error, if you have a problem following the guidelines, or if there is information that you feel is missing from this manual, please contact us at the above number so that we may resolve the issue immediately.

Restraint Identification

It is very important that in order to obtain the best possible service from Nordock Inc., please provide the model and serial number of the restraint whenever you contact us. Below is the same serial number decal that will be found on the left hand hook side plate (standing outside facing the restraint). Please record the information from the decal on the restraint in the area below. This will greatly reduce the possibility of improper parts being shipped to you.

		Phone 866-885-4276 www.nordockinc.com
Model:	<input type="text"/>	<input type="text"/>
Capacity:	<input type="text"/>	<input type="text"/>
Product may be covered by various U.S. and foreign patents or pending applications		



Copyright

This manual is copyright to Nordock Incorporated. All information, text, drawings, and technical data contained herein are for reference only. No part of this manual may be copied, altered, or stored on electronic media, and cannot be revealed to others for the purpose of competition.

Warranty

Nordock Inc. expressly warrants that the Model ATL-400 Vehicle Restraint shall remain free of defects in material and workmanship under normal use for One-Year from the date of delivery to the purchaser. The purchaser must maintain & operate the product in accordance with proper procedures. In the event the product proves defective in material or workmanship, Nordock Inc. will at its option within the first year either:

1. Replace the product or the defective without charge to the purchaser; or,
2. Alter or repair the product on site or elsewhere, as Nordock Inc. may deem advisable, without charge to the purchaser.

In addition to the above, the structural components are covered by an extended Five-Year period. In the event a structural component proves defective in years two through five, Nordock will provide a replacement part at no charge. Nordock Inc. is responsible for the cost to ship and install the replacement part during this extended period.

The warranty stated herein is that offered by Nordock Inc. and expressly disclaims all implied warranties including those of merchantability and fitness. This warranty does not cover any failure caused by improper installation, misapplication, overloading, abuse, negligence, or failure to do prescribed maintenance and protect the equipment from vehicle impact. Nordock Inc. or its representative assume no responsibility or liability for any incidental or consequential damages of any kind including loss of use of any equipment, damage or failure resulting from the use of unauthorized replacement parts or equipment modification, or damages resulting from the misuse of the equipment.

Nordock Inc. warranties extend only to the product itself. Nordock Inc. disclaims all liability of any kind arising out of the workmanship, methods and materials used by the installer or premature product wear, product failure, property damage or bodily injury arising from improper installation.

These warranties as stated herein are the exclusive remedies for all claims.



Safety Practices

The operators of this unit must read these safety practices before installing, operating or servicing the TRUCK-LOCK™. Failure to follow these safety practices may result in bodily injury, property damage or death.



WARNING

READ AND FOLLOW THE OPERATING INSTRUCTIONS CONTAINED IN THIS MANUAL BEFORE OPERATING THE TRUCK-LOCK™. If you do not understand the instructions, contact your supervisor for explanation and instruction on the safe operation of this unit.

Improper installation of the TRUCK-LOCK™ could result in serious injury or death to dock workers or other users of the restraint.

The following guidelines are to be used in conjunction with all laws, governances and codes in effect where the TRUCK-LOCK™ is installed.

1. Use by untrained people can cause property damage, serious injury and/or death. Your supervisor should instruct you on the safe and proper way to use the TRUCK-LOCK. Read and follow the complete OPERATING procedure on page 15 before use.
2. DO NOT USE THE TRUCK-LOCK IF IT IS NOT WORKING RIGHT. Tell your supervisor it needs repair.
3. Be certain all people in the driveway stand clear when the TRUCK-LOCK is being operated.
4. Do not stand in the driveway between the dock and a backing truck.
5. Keep all body parts clear of restraint guide tracks and moving parts at all times.
6. Do not install the TRUCK-LOCK anchor bolts into concrete of questionable integrity.
7. Do not load or unload any truck until you make certain that the TRUCK-LOCK has securely engaged the truck's ICC bar and the brakes are set. If the TRUCK-LOCK does not hitch the truck's ICC bar for any reason, BE CERTAIN TO CHOCK THE TRUCK WHEELS BEFORE PROCEEDING WITH LOADING OR UNLOADING.
8. Do not use the TRUCK-LOCK as a step.
9. All electrical troubleshooting and repair must be done by a qualified technician and must meet all applicable codes. Before doing any electrical work, make certain the power is disconnected and properly tagged or locked out.

10. If the TRUCK-LOCK fails to operate using the procedures contained in this manual, do not use the TRUCK-LOCK. Contact Nordock Inc. or an authorized service representative for service.
11. Whenever any maintenance or repair is to be performed on the restraint, barricade the area around the dock floor and driveway and place clear signage on the perimeter that the dock and restraint are not to be operated.
12. If you have any questions, contact your supervisor or your local Nordock Incorporated representative.

Labels

The labels and decals on the TRUCK-LOCK must be kept in clean, legible condition at all times. The diagram below shows the decals and their placement on the restraint. Please check their condition on a daily basis, and replace them immediately if they become unreadable.

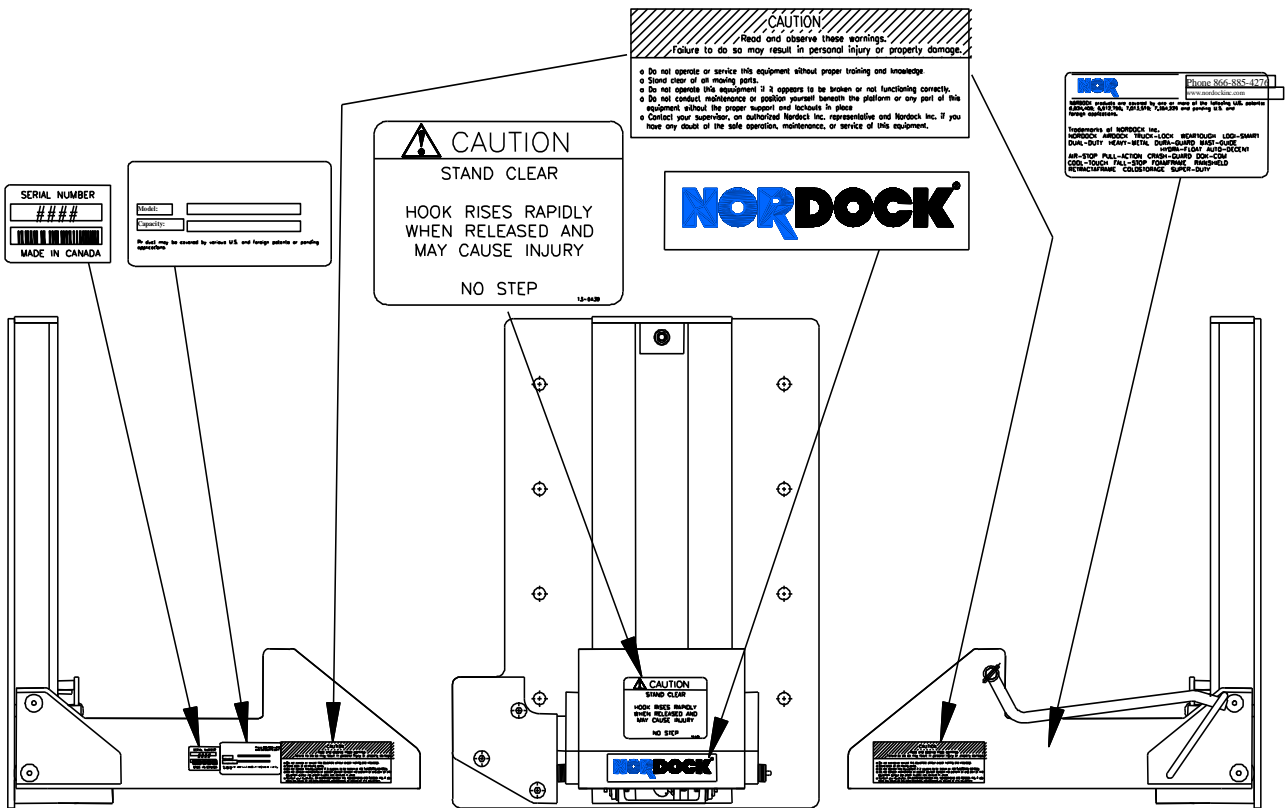

Installation



WARNING

IMPROPER INSTALLATION OF THIS TRUCK-LOCK COULD RESULT IN SERIOUS INJURY OR DEATH TO DOCK WORKERS OR OTHER RESTRAINT USERS

A typical TRUCK-LOCK restraint installation is shown below.

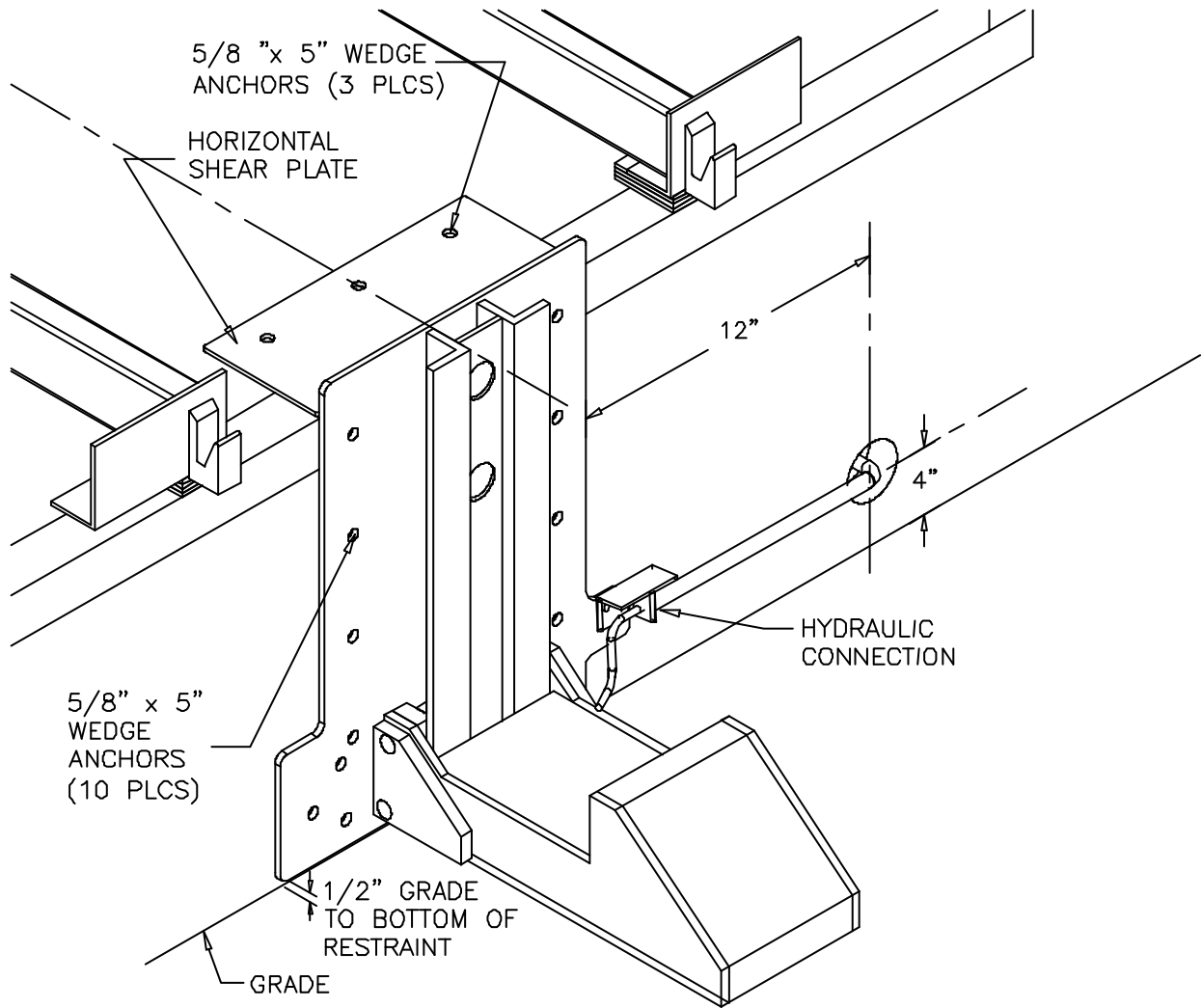

The following installation materials are included with the restraint:

- 13 pcs. 5/8" x 5" concrete wedge anchors
- 1 pc horizontal shear plate

All other materials required are to be provided by the installer.

Mounting Requirements

1. The dock face on which the TRUCK-LOCK is to be mounted must be flat and vertically plumb for correct operation. If the dock face is not flat, it may be necessary to use shims behind the backplate of the restraint or to modify the dock face to provide a flat mounting surface. If shimming is required, it is necessary to place shims at all of the anchor hole locations where the backplate does not contact the wall. This will prevent distortion of the backplate when the anchors are tightened.
2. The TRUCK-LOCK vehicle restraint requires a 4" bumper projection from the front of the bumper to the rear of the back plate of the restraint. Less than 4" of projection can allow trailer ICC bars to damage the restraint.
3. Some types of dock levelers that use lip saddles may interfere with the TRUCK-LOCK vehicle restraint. Depending upon the lip length, dock height, bumper projection, use of standoffs etc., modification to the restraint and/or dock leveler may be required. Consult the factory for specific applications.
4. The standard concrete anchors (5/8" x 5" wedge style) provided with this restraint may only be used on docks constructed of solid concrete. Docks constructed of other materials require special mounting considerations. Contact your local Nordock distributor for application specific information.
5. A 3/8" gap is required between the dock leveler front angle and the pit floor for installation of the horizontal shear plate.
6. Do not install the TRUCK-LOCK anchor bolts into concrete of questionable integrity.
7. If the driveway beneath the TRUCK-LOCK is affected by frost, additional clearance between the TRUCK-LOCK and the driveway may be required to prevent damage due to heaving.

Tools Required

- Welder
- Hammer drill with 5/8" diameter masonry bit
- 15/16" Wrench
- General hand tools
- Touch up paint (Silver)
- Torque wrench (100 ft-lbs. min.)
- 5/8" Wrench

Installation with Pit Type Levelers

1. Place barricades around pit on dock floor and driveway while installing the TRUCK-LOCK.
2. The horizontal shear plate **MUST BE INSTALLED** to achieve the full rated restraining capacity of the TRUCK-LOCK.

The installation method for the horizontal shear plate will depend upon the height of the front curb steel off grade and if there is a sufficient gap under the dock leveler front angle.

The diagrams below illustrate acceptable shear plate mounting methods for the most common types of restraint installations.

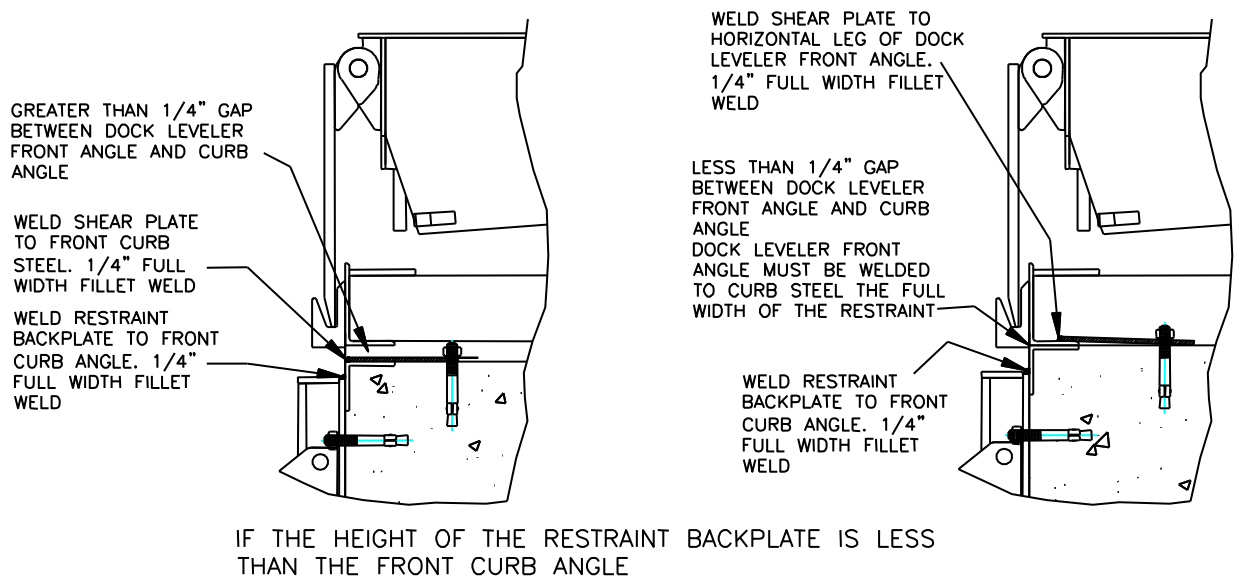
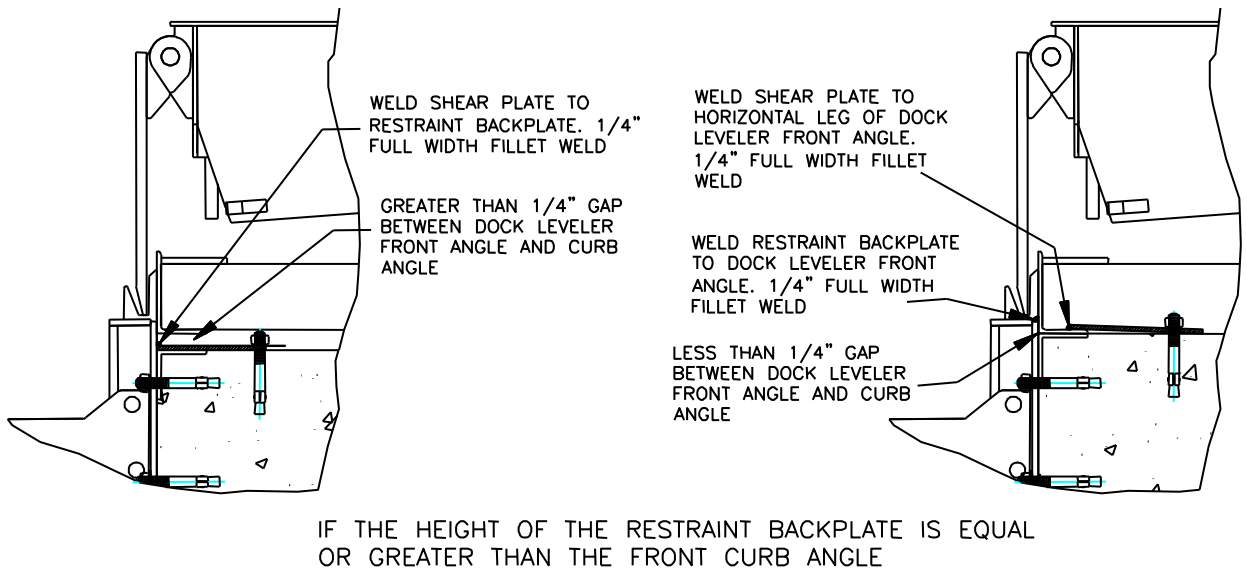

Please consult the factory if your particular site conditions prohibit installation of the shear plate using the above methods.



WARNING

ALWAYS USE DOCK LEVELER MAINTENANCE SUPPORT WHEN WORKING UNDER A DOCK LEVELER RAMP OR LIP

3. If there is sufficient clearance, insert the horizontal shear plate into the gap between the dock leveler front angle and the pit floor.

Otherwise use one of the methods illustrated on the previous page.

4. Place the bottom of the TRUCK-LOCK $\frac{1}{2}$ " above the driveway and centre it with the dock leveler pit.
 - a. If the horizontal shear plate is above the top of the backplate, weld the full width of the shear plate to the dock leveler front angle. If there is no dock leveler front angle (clean frame design), weld the full width of the shear plate to the front pit curb angle.
 - b. If the horizontal shear plate is level with or below the top of the backplate, tack the shear plate to the backplate at both ends. Pull the restraint and shear plate away from the dock and weld the full width of the plate on the topside using a $\frac{1}{4}$ " fillet. Refer to adjacent diagram.

Paint welded areas to prevent rust.

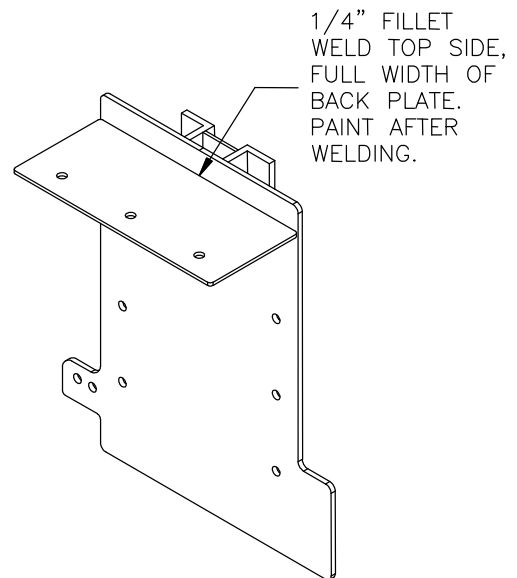

5. Slide the TRUCK-LOCK and shear plate back into position.
6. Before anchoring the TRUCK-LOCK, operate the dock leveler through its full range of motion.
 - a. Check that the TRUCK-LOCK does not interfere with the below dock operation and that the dock leveler lip does not come to rest on the TRUCK-LOCK in such a way that it supports the weight of the dock leveler.
 - b. In the full below dock position, check that the pendant dock leveler lip does not project beyond the face of the bumpers when it is resting on the top of the restraint.

⚠ WARNING

Improper installation that allows the pendant dock leveler lip to support the weight of the dock leveler could result in serious injury or death. It is sometimes necessary to install lip deflector plates to prevent the possibility of the pendant lip storing on top of or behind the restraint backplate.

An optional bolt-on lip deflector plate is available for use with this restraint. It is shown in the diagram below. If the optional deflector is insufficient to prevent the dock leveler lip from resting on top of or in behind the restraint, the installer must provide additional steel.

If the optional deflector plate interferes with the storing of the dock leveler lip, it may be removed.

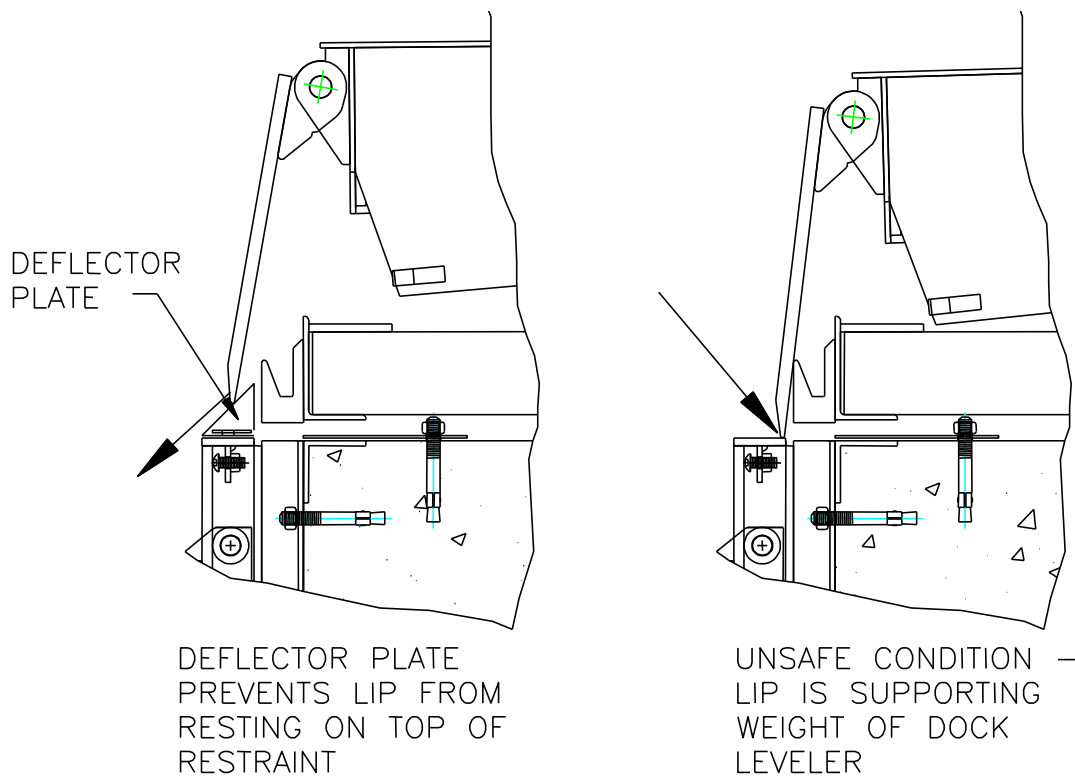

- Anchor the TRUCK-LOCK backplate to the dock face using the wedge anchors provided. The anchor bolts must be torqued to 90 ft-lbf to achieve maximum holding strength.

NOTE

Anchors must be installed in a minimum of six (6) back plate-mounting holes. The anchors should be installed as the holes are drilled to prevent the TRUCK-LOCK from shifting.

- Anchor the shear plate to the pit floor using the concrete anchors provided. The anchor bolts must be torqued to 90 ft-lbf to achieve maximum holding strength.

⚠ WARNING

Before doing any electrical and hydraulic work, the power must be disconnected and properly locked/tagged off. Failure to do so could result in death or serious injury. All electrical and hydraulic work must meet all applicable codes and be carried out by a qualified technician.

NOTE

The control voltage for this restraint is 24 VDC. All motor power wires or other high voltage wires should be run in a separate conduit.

9. Mount the control box inside the building, to the left of the doorway, 4 ft. above the floor. Refer to diagram below.

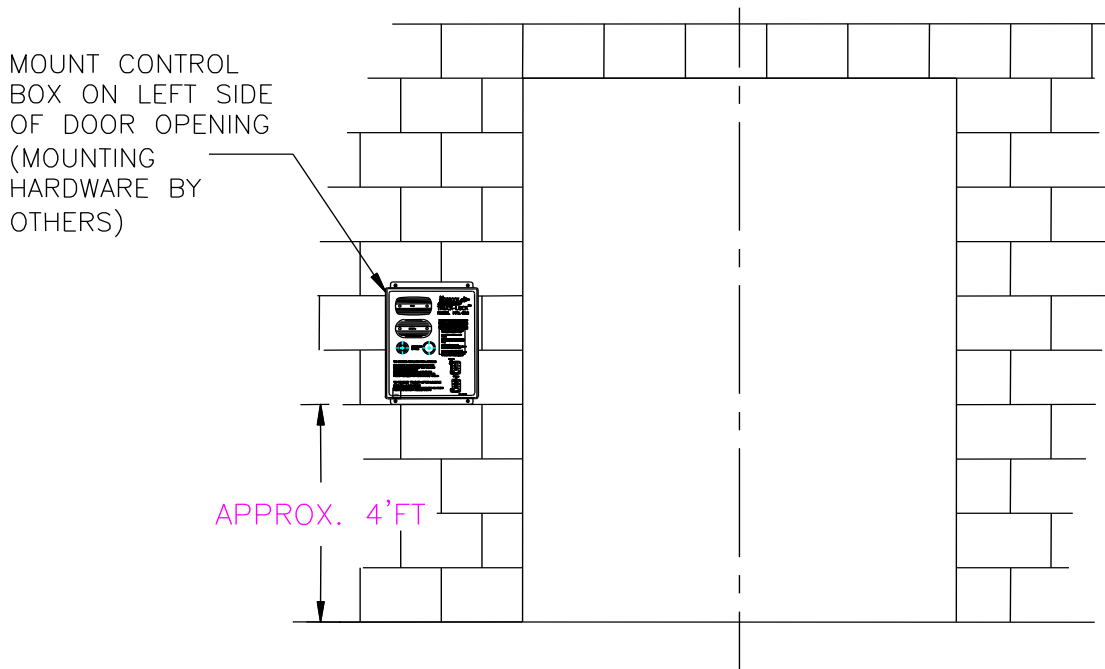

10. The outside signal light is to be placed approximately 9 ft above the driveway on the driver's side of the door opening as shown in the diagram on the next page. Drill a hole through the wall at the centre of the signal light mounting position.
11. Run a length of 16/3 electrical cable (not supplied) from the control box location through the wall. Make connections in panel and signal light assembly as indicated in the wiring diagram located at the back of this manual.

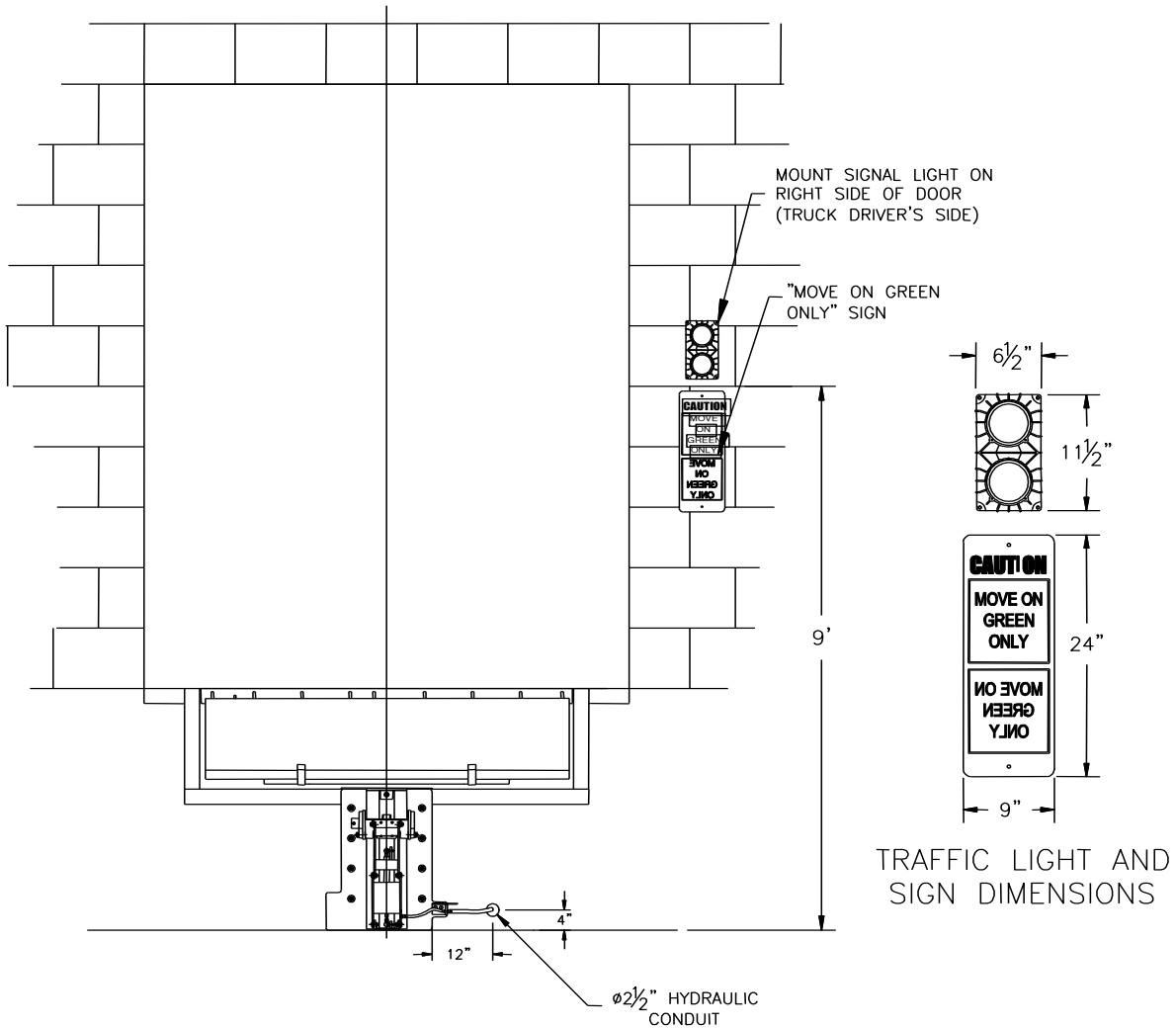

12. Fasten the signal light housing to the wall.
13. Mount the "Move On Green Only" sign provided to the exterior wall under the signal light as shown in the diagram above.
14. If this installation includes an optional dock leveler "stored" limit switch, remove the jumper between terminals 9 & 10 and wire in the normally open contact. This will prevent the restraint from being released until the dock leveler is stored.
15. Bring 110/1/60 power to panel and wire according to the diagram located at the back of this manual. **DO NOT APPLY POWER AT THIS TIME.** Running the pump without oil can cause permanent damage.
16. Cap both ends of the 16' length of 1/4" hydraulic hose (supplied) with the restraint.
17. Route the hose through the conduit from the control box to the bulkhead hose connection on the restraint back plate.
18. Clip the hose to the wall as necessary to prevent any tension on the hose end.
19. Connect one end of the hose to the control box port.

20. Connect the other end of the hose to the bulkhead fitting on the backplate hose-mounting bracket.
21. Tighten all connections.
22. Remove the filler cap from the hydraulic pump reservoir.
23. Using the supplied hydraulic oil, fill the reservoir to the top. Leave the filler cap off, as oil will need to be added while the pump is running.
24. Apply power to the control panel.
25. The outside light should be a solid green and the inside light a solid red. If the lights are not on or not as described, verify power and all field wiring connections.
26. Press and release the "LOCK" button. The pump will turn on and the outside light will change to red.
27. After the pump runs for several seconds, the hook will slowly start to rise. The motion will be "jerky" at first due to the air in the line. This is normal.
28. As the hook raises and the accumulator charges, the oil level in the reservoir will drop significantly. Add oil as the motor is running to keep the reservoir approximately 1/2 full.
29. The pump will shut off automatically when the pressure reaches a preset value.
30. Check for oil leaks at all hose connections.
31. Press the "RELEASE" button to store the hook
32. Add hydraulic oil as necessary to bring the fluid level up to the "MAX" line on the side of the reservoir.
33. Replace filler cap on hydraulic oil reservoir.

NOTE

Before the hook can be raised again, the selector switch on the panel front must be turned to the "TRUCK LEAVE" position. This will change the outside light to green and reset the control relays to allow the hook to be raised again.

34. Operate the TRUCK-LOCK control box "LOCK" and "RELEASE" pushbuttons several times to release any remaining air that is trapped in the system.
35. Verify that the hook raises and lowers smoothly.
36. Verify correct operation as follows:

- a. One light must be on, both interior and exterior at all times.
 - b. With the restraint in the stored position, the exterior light will be a solid GREEN and the interior light will be solid RED.
37. If the lights do not operate as described, there is a field-wiring problem. Turn off the power and check the wiring per the Wiring Diagram at the back of this manual. Rewire as required.
38. Instruct the dock workers how to correctly use the TRUCK-LOCK. The Operating Procedure can be found in the next section.

Installation of Optional Driveway Mounting Plate

When the optional driveway mounting plate is used, the driveway material must be concrete. For driveway materials other than concrete, a stepped concrete pad must be poured as shown next page. Allow concrete to properly cure before installing restraint.

Place plate on driveway or concrete pad.

Place bottom of TRUCK-LOCK on the driveway plate. Keep both the TRUCK-LOCK and driveway plate centered with the dockleveler pit.

Make sure the horizontal shear plate is welded to the restraint back plate as previously noted in Installation Instruction 4a and b.

Weld the bottom of the TRUCK-LOCK back plate to the driveway plate, as shown on next page. Paint welded areas to prevent rust.

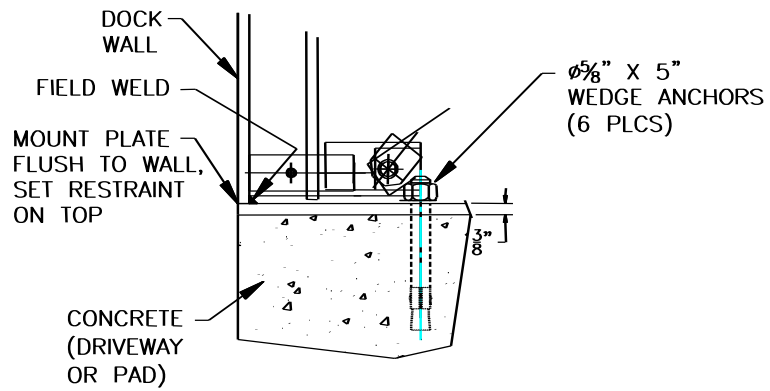
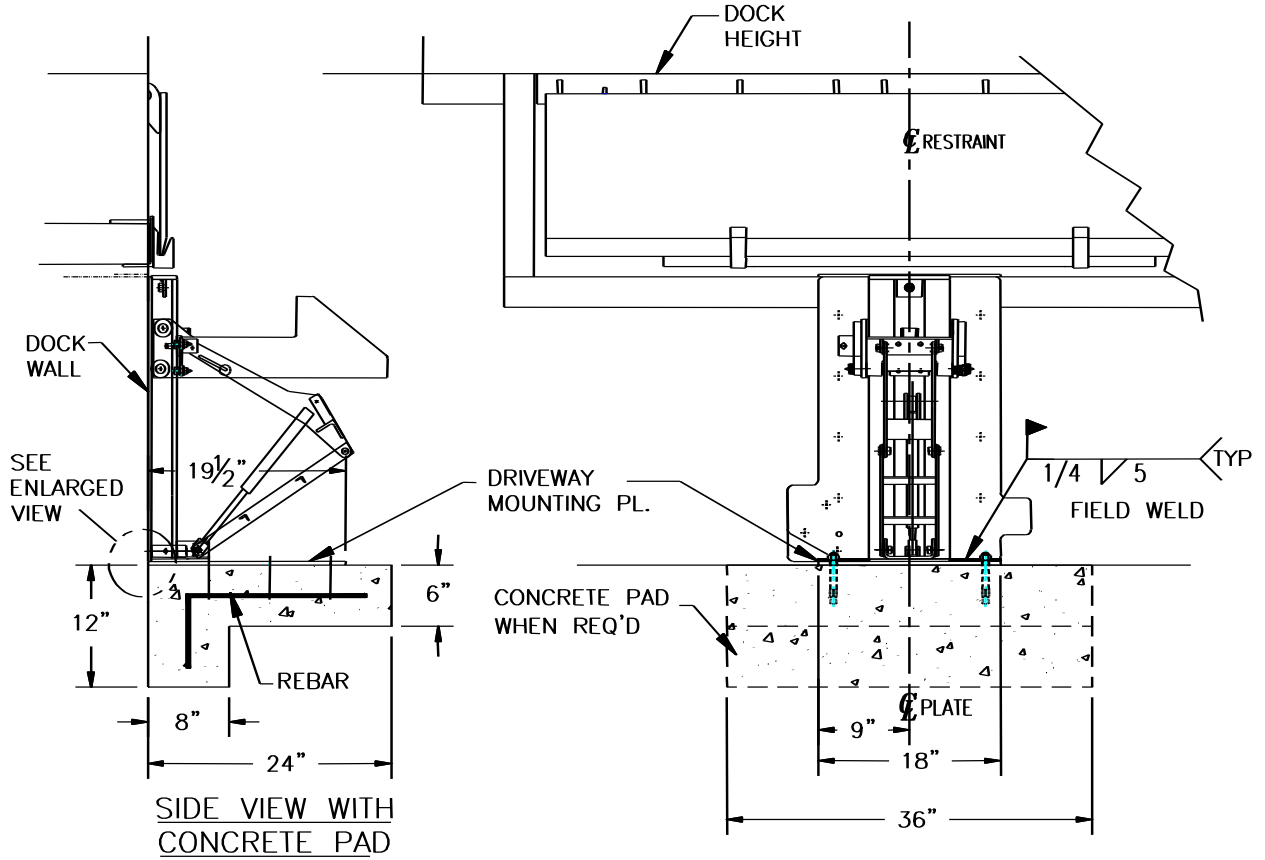

ENLARGED VIEW
RESTRAINT/PLATE
AT WALL

Operating Procedure



WARNING

Before operating or maintaining this truck restraint, read and follow the safety practices contained in this manual. Failure to follow the guidelines in this manual and those in effect in the workplace can result in serious bodily harm and equipment damage.

Do not load or unload any truck unless you make certain the TRUCK-LOCK has securely engaged the truck's ICC bar and that the truck brakes are set. If the TRUCK-LOCK does not engage the truck's ICC bar for whatever reason, THE TRUCK'S WHEELS MUST BE CHOCKED BEFORE LOADING OR UNLOADING CAN BEGIN.

Failure to store the TRUCK-LOCK when not in use could result in damage to the TRUCK-LOCK and incoming trucks.

To Hitch Truck:

(Initial conditions: – hook stored – outside light flashing green – inside light red)

1. Press and release the “LOCK” button. The hook will raise to engage the truck's ICC bar.
2. The outside traffic light will change to flashing red and the inside light will change to GREEN.

VISUALLY CHECK ICC bar engagement.

3. If the truck cannot be hitched, press “RELEASE” to store hook.
4. Secure the trailer by chocking the wheels on BOTH sides.
5. Turn the RESTRAINT BYPASS” selector to the “ON” position. The inside light changes to GREEN.
6. The dock leveller can now be used to load/unload the truck.

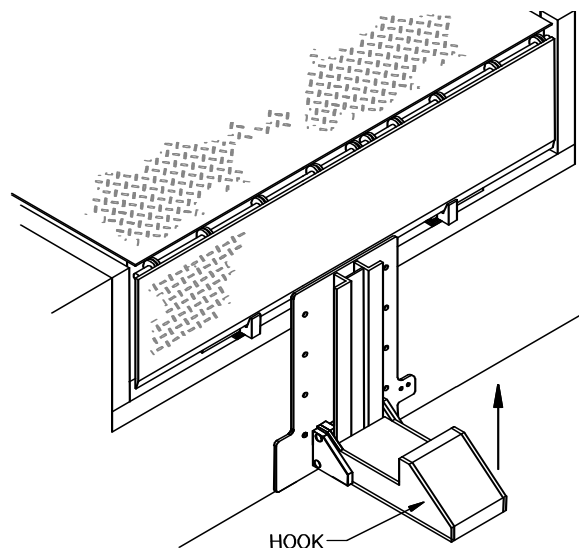

To Release Truck:

1. Ensure the dock leveler is stored.
2. The “RESTRAINT BYPASS” selector must be turned to the “OFF” position before the hook can be released.
3. Press the “RELEASE” button. If raised, the hook will disengage and lower to its stored position.

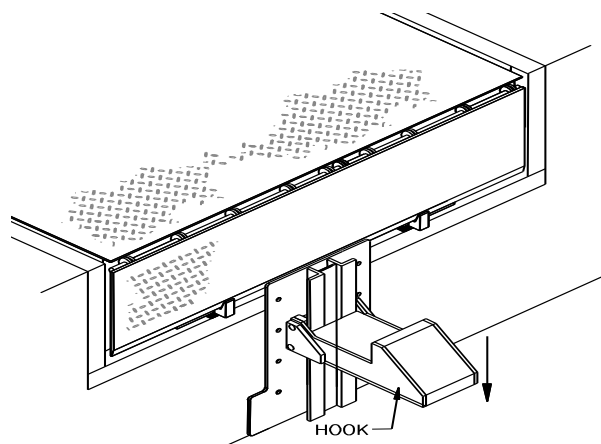

VISUALLY CHECK that the hook has fully lowered.

4. The interior light will switch to a solid red and the outside light will change to a flashing GREEN.
5. The truck may now pull out.

Troubleshooting

Restraint Operating Function Check

Initial Conditions:

- RESTRAINT BYPASS selector switch is in the “OFF” position.
- Hook stored – Inside solid red light – Outside light flashing green.

Press the LOCK pushbutton:

- The outside light will change to flashing red.
- The hook will raise.
- The cylinder will extend fully and the pump will shut off at 1000 psi.
- The inside light will change to green.

Turn the “RESTRAINT BYPASS” selector switch to the “ON” position:

- The inside light will change to a solid green
- The outside light will remain flashing red

Press the RELEASE pushbutton:

NOTE: The “RESTRAINT BYPASS” selector switch must be in the “OFF” position before the hook can be released.

- The inside light will change to a solid red
- The hook will lower fully
- The outside light will change to flashing green

NOTE: Visually check to make sure the hook has fully lowered before instructing the truck driver to leave.

<u>PROBLEM</u>	<u>CAUSE</u>	<u>CORRECTIVE ACTION</u>
Motor runs but hook will not raise	1. Hook jammed in track.	Check track for debris and that rollers are not binding.
	2 Low hydraulic oil level in reservoir.	Add fluid as necessary.
	3 Hydraulic oil leak.	Check all hoses and fittings and inside control panel Replace or repair as necessary.
	4. Malfunctioning solenoid raising valve.	Check valve and coil; replace as necessary.
Motor does not run – inside and outside lights still work.	Blown 12A control fuse FU2.	Check & replace if necessary.
	Bad motor power relay.	Check & replace if necessary.
	Bad motor.	Check & replace if necessary.
No inside or outside lights and motor does not run	Blown 5A main control fuse (FU1)	Check & replace if necessary.
	No power to control panel	Check incoming power and troubleshoot as necessary

Maintenance Schedule

WARNING

Before servicing this restraint, read and follow the safety practices contained in this manual. Failure to follow the guidelines in this manual and those in effect in the workplace can result in serious bodily harm and equipment damage.

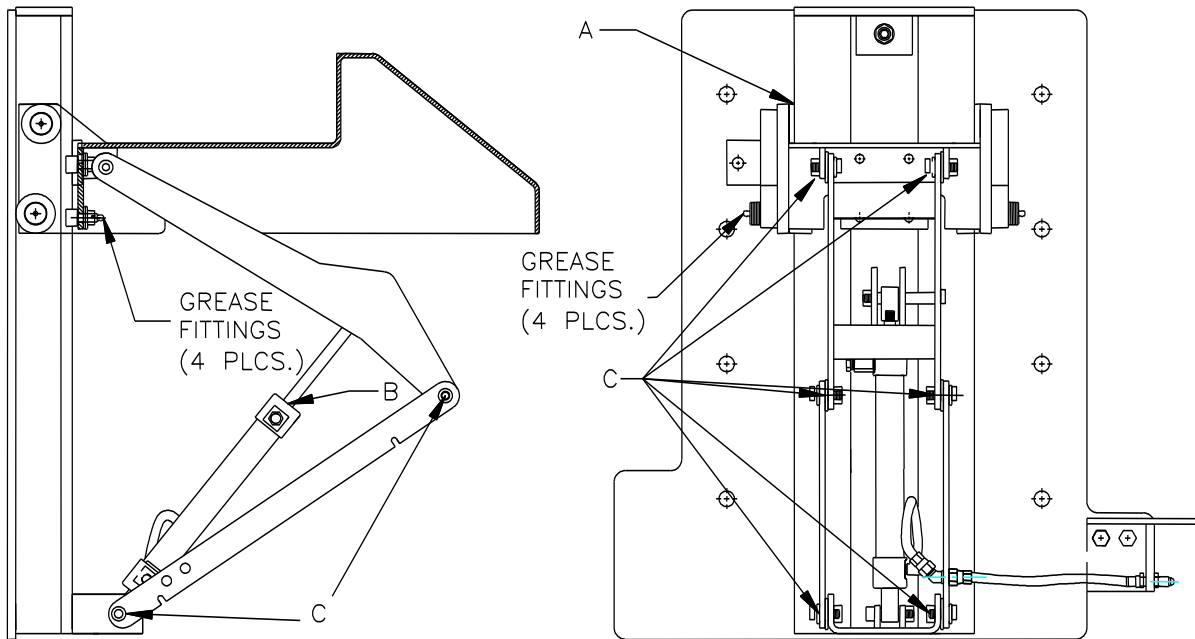

Item	Lubrication	Inspection	Cleaning
Grease Fittings (8 locations)	Every 90 days Using MP grease	None	Remove debris as required
- A - Track & Rollers	None required	Weekly – Check for bent track or damaged rollers	Remove debris as required
- B - Cylinder	None required	Monthly – Check for leaks	Remove debris from rod as required
- C - Pivot Points (6 locations)	None required	Monthly – Check for loose fasteners- tighten as required	Remove debris as required
Driveway Area Around Restraint	None required	None	As required to remove debris
Signal Lights Interior & Exterior	None required	Daily check that all bulbs are working	Clean lenses as required
Concrete Anchors (11 locations)	None required	Weekly check that all anchors are tight. Re-tighten if necessary	None required
Hydraulic Oil on motor/pump unit in control box	Yearly – change hydraulic oil	Monthly - Check fluid level on hydraulic pump in control box	None required
Hydraulic Hoses & Fittings	None required	Monthly – all hoses, fittings and inside control box for evidence of leakage	Clean up oil as necessary and repair leaks

Acceptable Lubricants and Oils

Hydraulic

Oils used in the hydraulic system must meet minimum ISO grade 22 standard. E.G.:

COMMERCIAL OIL MULIT-VIS MV22
MOBIL AERO HFA (49011)
EXXON UNIVIS GRADE J13
TEXACO AIRCRAFT OIL #1537BB
U.S.OIL CO. #5606 (LOW TEMP)
SHELL TELLUS T22

Grease

Grease must be CHEVRON RPM Arctic grease EP NLGI 1 (GC-LB) or equivalent.

Parts Replacement



WARNING

Before servicing this restraint, read and follow the safety practices contained in this manual. Failure to follow the guidelines in this manual and those in effect in the workplace can result in serious bodily harm and equipment damage.

Always replace traffic light bulbs with 28VDC, #2233 bulbs or equivalent. Using 12V automotive type bulbs, such as a #1156 will cause damage to the control panel components that will not be covered under warranty.

NOTE

Before removing the stop plate from the top of the track, ensure that the hook is not under pressure against the bottom of it. This will help avoid pinching fingers or other body parts.

Removing Hook From Track

If the hook has to be removed to replace damaged or worn parts, the following procedure must be used to avoid personal injury.

1. Press the "LOCK" pushbutton and allow the hook to reach the top of its travel.
2. Block up the restraint hook to support its weight when hydraulic pressure is removed.
3. Lock-Out and Tag the power OFF at the disconnect supplying the control panel.
4. Unscrew retaining bolt from front of track and remove stop plate.
5. Remove the upper cylinder bolt and jam nut.

NOTE

Do not use a pry bar on the rod as it may damage the surface causing premature failure of the cylinder.

6. Once the rod end of the cylinder has been disconnected, the hook can be lifted out of the track and lowered to the ground in front of the back-plate without disconnecting any of the linkages.

Re-Installing Hook Into Track

1. Lower hook back into track and block up at a height so that the cylinder may be re-installed easily.
2. Position the cylinder end block between the upper mounting brackets and from the left side of the arm assembly, reinsert the 5 ½" long bolt through the brackets and cylinder end, replacing the jam nut and nut.
3. Re-install stop plate and retaining bolt.
4. Turn on power to the control panel and press "LOCK" to raise the hook up off the support blocking
5. Remove blocking and press "RELEASE" to allow the hook to store
6. Turn RESTRAINT BYPASS selector switch to "OFF" to change outside light to green.

Wiring Diagram

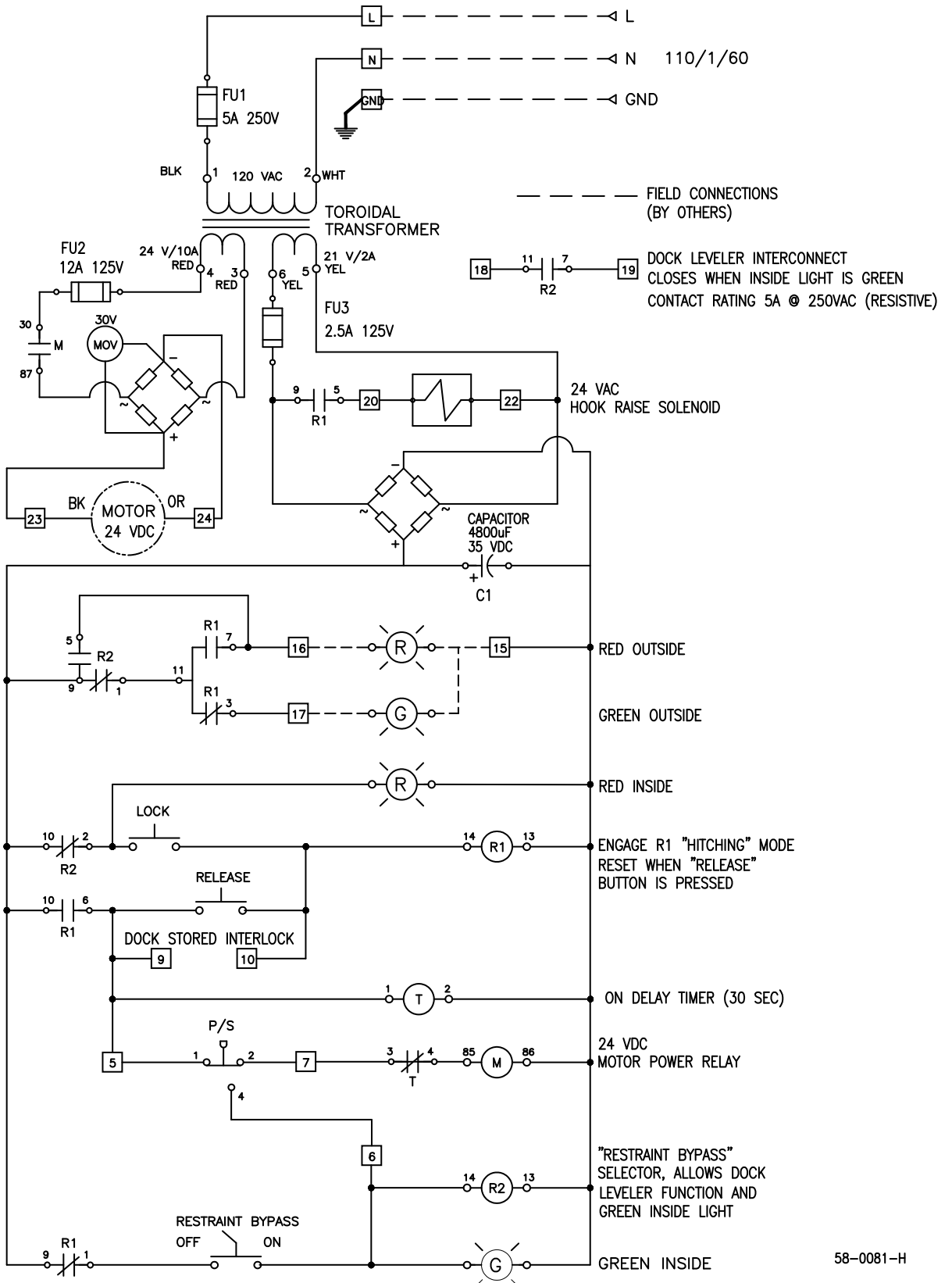

58-0081-H

Parts List

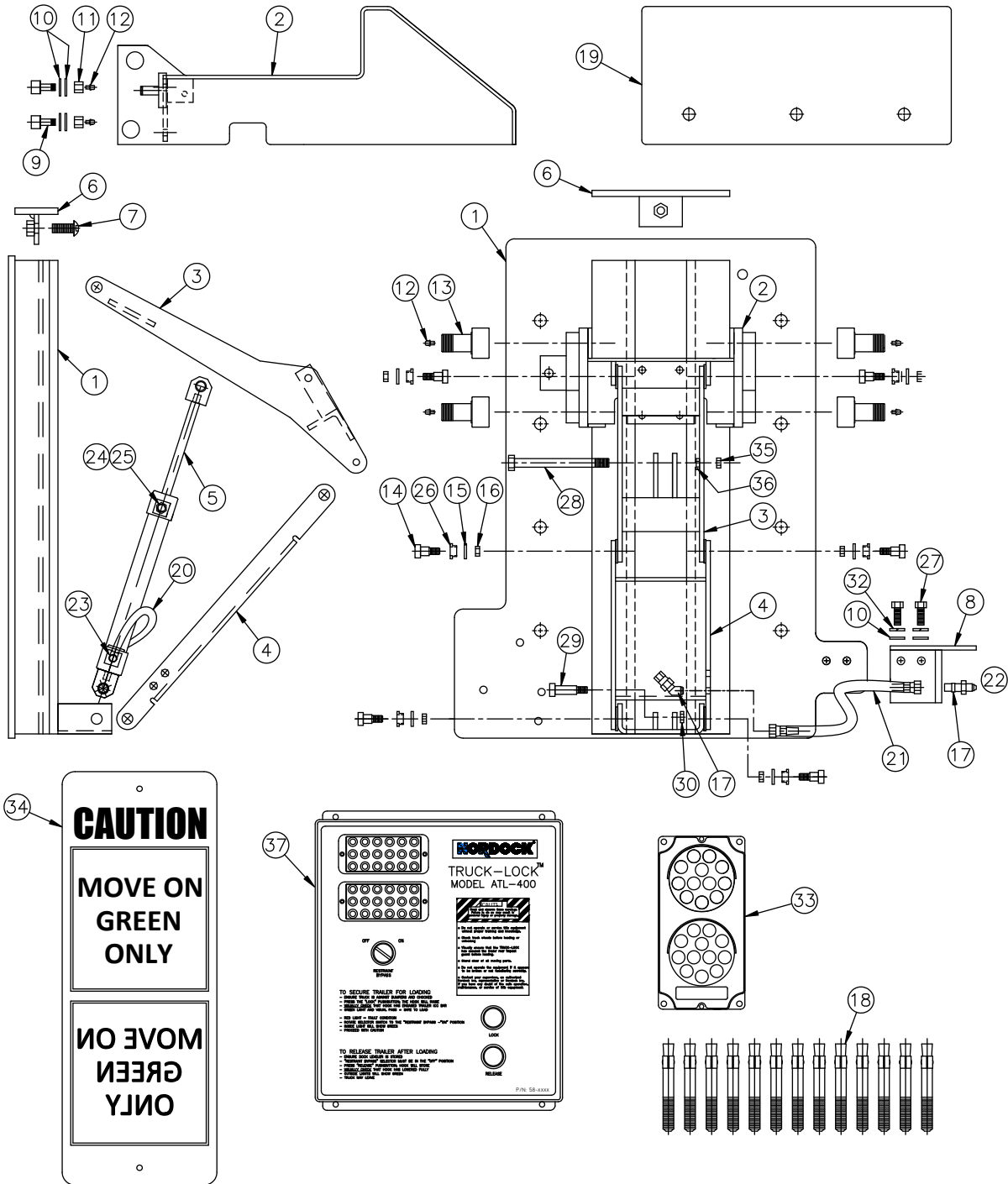

Item	Qty.	Description / Model	P/N	Note
1	1	Back Plate Weldment	52-0158	
2	1	Hook Weldment	52-0102	
3	1	Triangle Arm Weldment	52-0157	
4	1	Tension Arm	53-0123	
5	1	Hydraulic Cylinder, ATL Series Restraint	Cylinder with ends C/w adapter, breather (24,25)	C1-0079 C1-0091
6	1	Stop Plate Weldment	52-0106	
7	1	Bolt, Button Head, 1/2" x 1 1/2" Stainless Steel	13-0966	
8	1	Hose Mounting Bracket, ATL Series Restraint	52-0116	
9	4	Bearing Cam Follower, Ø3/4"	13-0915	
10	14	Washer, 3/8" SAE, ZP	13-0203	
11	4	Nut, 3/8"-24 x 1/2" Nylock, ZP	13-0969	
12	8	Grease Fitting, 3/16", Drive-in	13-0655	
13	4	Bearing, Cam Follower, Ø 1-3/4", Heavy Stud	13-0916	
14	6	Bolt, Shoulder, 1/2" x 1/2", ZP	13-0965	
15	6	Washer, Flat, 1/2", STD, ZP	13-0267	
16	6	Nut, Hex, Nylock Jam 3/8"-16	13-1331	
17	2	Fitting, Hydraulic (#4) 45 Degrees, Bulkhead	13-1170	
18	13	Anchor, Concrete, Wedge, Ø5/8" x 5", ZP	13-0799	
19	1	Horizontal Shear Plate	53-0108	
20	1	Hose, Hydraulic (1/8) x 6 3/4" Long	13-1232	
21	1	Hose, Hydraulic (#4) x 7 1/4" Long	52-0164	
22	1	Hose, Hydraulic (1/4) x 16' Long, SAE100 R1AT	52-0165	
23	1	Fitting, Hydraulic (#4) 90° 7/16 MORB x 7/16 MJIC	13-0905	
24	1	Adapter, Str. 7/16 (4) MORB ¼ (4) FNPT	13-0489	
25	1	Breather, Sintered Bronze	13-1383	
26	6	Bushing, Flange, 1/2" ID x 5/8" OD x 3/8", Oilite	13-0953	
27	2	Bolt, 3/8" x 1"	13-0843	
28	1	Bolt, Hex Head, ½" x 5 1/2" long, plated	13-1638	
29	1	Shoulder Bolt, ½" x 1 ¼" long, 3/8" thread	13-1365	
30	1	Jam Nut, 3/8"	13-1021	
32	2	Washer, Lock, 3/8"	13-0767	
33	1	Outside Traffic Light, Red and Green	13-3282	
34	1	Sign, Outside Caution	23-0124	
35	1	Nut, ½" Nylock	13-0750	
36	1	Jam Nut, ½" plated	13-1639	
37	1	Control Panel	58-0182	
38	1	Pressure Switch, #4 SAE (not shown)	13-1835	