

TRUCK-LOCK™ SERIES
MTL-100

Low Profile
Vehicle Restraint Manual

Owner's Manual

This manual applies to MTL-100 series restraints manufactured after 2013/06/01
With serial numbers 25005 and greater.

P/N: 59-0001 Rev. J

NORDOCK INC.

Website: nordockinc.com ~ Email: sales@nordockinc.com ~ Toll free: 866-885-4276
Nordock Inc. reserves the right to make changes to specifications without notice or obligation. Nordock products may be covered by various U.S. and foreign patents or pending applications.

Contents

Contents	1
Preface	2
Problems, Errors and Omissions	2
Restraint Identification	2
Copyright	2
Warranty	3
Safety Practices	4
Labels	5
Installation	6
Mounting Requirements.....	7
Tools Required	7
Installation with Pit Type Levelers.....	8
Installation of Optional Driveway Mounting Plate.....	12
Operation Procedure	13
To Hitch Truck:	13
To Release Truck:	13
Maintenance Schedule.....	14
Parts Replacement.....	15
Removing Hook From Track.....	15
Re-installing Hook Into Track.....	15
Parts List	16

Preface

PLEASE READ AND UNDERSTAND THIS MANUAL COMPLETELY

This manual gives detailed information and instruction on how to operate and maintain your equipment correctly. Failure to do so could result in personal injury, and/or equipment damage. Please consider this manual a permanent part of the unit and keep it near the restraint for reference whenever needed.

If you have any questions about this manual, the restraint, its components, or our products and services, please call us at 1-866-885-4276 and we will be happy to assist you. With proper care and maintenance, this restraint is designed to work effectively and efficiently for many years to come.

Problems, Errors and Omissions

This manual has been prepared with the utmost care and attention to detail to provide accurate parts and service information should the need arise. Nordock Incorporated believes this manual will provide the operators of this restraint all the necessary information required to operate and maintain it for many years. If you believe there is an error, if you have a problem following the guidelines, or if there is information that you feel is missing from this manual, please contact us at the above number so that we may resolve the issue immediately.

Restraint Identification

It is very important that in order to obtain the best possible service from Nordock Inc.,

		Phone 866-885-4276 www.nordockinc.com
Model:	<input type="text"/>	
Capacity:	<input type="text"/>	
<small>Product may be covered by various U.S. and foreign patents or pending applications</small>		



Copyright

This manual is copyright to Nordock Incorporated. All information, text, drawings, and technical data contained herein are for reference only. No part of this manual may be copied, altered, or stored on electronic media, and cannot be revealed to others for the purpose of competition.

Warranty

Nordock Inc. expressly warrants that the Model MTL-100 Vehicle Restraint shall remain free of defects in material and workmanship under normal use for One-Year from the date of delivery to the purchaser. The purchaser must maintain & operate the product in accordance with proper procedures. In the event the product proves defective in material or workmanship, Nordock Inc. will at its option within the first year either:

1. Replace the product or the defective without charge to the purchaser; or,
2. Alter or repair the product on site or elsewhere, as Nordock Inc. may deem advisable, without charge to the purchaser.

In addition to the above, the structural components are covered by an extended Five-Year period. In the event a structural component proves defective in years two through five, Nordock will provide a replacement part at no charge. Nordock Inc. is responsible for the cost to ship and install the replacement part during this extended period.

The warranty stated herein is that offered by Nordock Inc. and expressly disclaims all implied warranties including those of merchantability and fitness. This warranty does not cover any failure caused by improper installation, misapplication, overloading, abuse, negligence, or failure to do prescribed maintenance and protect the equipment from vehicle impact. Nordock Inc. or its representative assume no responsibility or liability for any incidental or consequential damages of any kind including loss of use of any equipment, damage or failure resulting from the use of unauthorized replacement parts or equipment modification, or damages resulting from the misuse of the equipment.

Nordock Inc. warranties extend only to the product itself. Nordock Inc. disclaims all liability of any kind arising out of the workmanship, methods and materials used by the installer or premature product wear, product failure, property damage or bodily injury arising from improper installation.

These warranties as stated herein are the exclusive remedies for all claims.



Safety Practices

The operators of this unit must read these safety practices before installing, operating or servicing the TRUCK-LOCK™. Failure to follow these safety practices may result in bodily injury, property damage or death.



WARNING

READ AND FOLLOW THE OPERATING INSTRUCTIONS CONTAINED IN THIS MANUAL BEFORE OPERATING THE TRUCK-LOCK™. If you do not understand the instructions, contact your supervisor for explanation and instruction on the safe operation of this unit.

Improper installation of the TRUCK-LOCK™ could result in serious injury or death to dock workers or other users of the restraint.

The following guidelines are to be used in conjunction with all laws, governances and codes in effect where the TRUCK-LOCK™ is installed.

1. Use by untrained people can cause property damage, serious injury and/or death. Your supervisor should instruct you on the safe and proper way to use the TRUCK-LOCK. Read and follow the complete Operating Procedure on page 11 before use.
2. DO NOT USE THE TRUCK-LOCK IF IT IS NOT WORKING RIGHT. Tell your supervisor it needs repair.
3. Be certain all people in the driveway stand clear when the TRUCK-LOCK is being operated.
4. Do not stand in the driveway between the dock and a backing truck.
5. Keep all body parts clear of restraint guide tracks and moving parts at all times.
6. Do not install the TRUCK-LOCK anchor bolts into concrete of questionable integrity.
7. Do not load or unload any truck until you make certain that the TRUCK-LOCK has securely engaged the truck's ICC bar and the brakes are set. If the TRUCK-LOCK does not hitch the truck's ICC bar for any reason, BE CERTAIN TO CHOCK THE TRUCK WHEELS BEFORE PROCEEDING WITH LOADING OR UNLOADING.
8. Do not use the TRUCK-LOCK as a step.
9. If the TRUCK-LOCK fails to operate using the procedures contained in this manual, do not use the TRUCK-LOCK. Contact Nordock Inc. or an authorized service representative for service.

10. Whenever any maintenance or repair is to be performed on the restraint, barricade the area around the dock floor and driveway and place clear signage on the perimeter that the dock and restraint are not to be operated.
11. If you have any questions, contact your supervisor or your local Nordock Incorporated representative.

Labels

The labels and decals on the TRUCK-LOCK must be kept in clean, legible condition at all times. The diagram below shows the decals and their placement on the restraint. Please check their condition on a daily basis, and replace them immediately if they become unreadable.

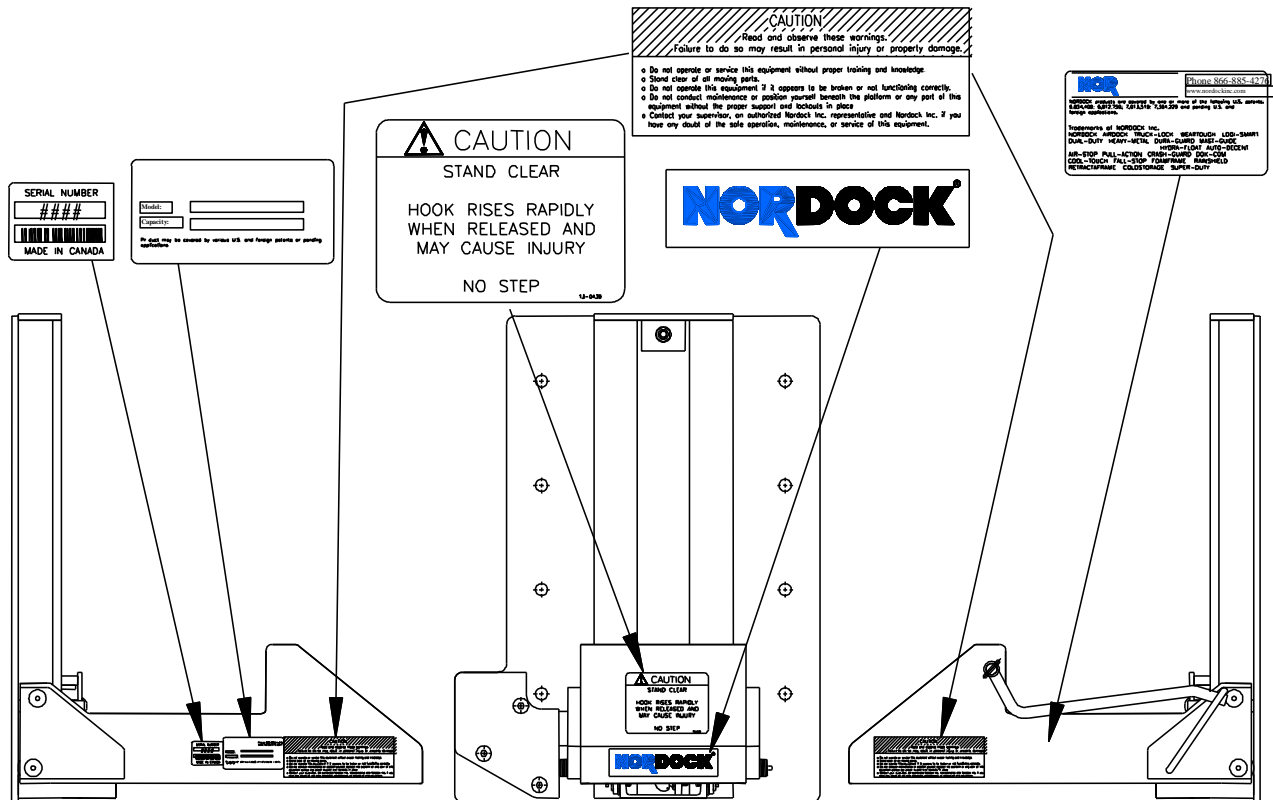

Installation

WARNING

IMPROPER INSTALLATION OF THIS TRUCK-LOCK COULD RESULT IN SERIOUS INJURY OR DEATH TO DOCK WORKERS OR OTHER RESTRAINT USERS

A typical TRUCK-LOCK restraint installation is shown below.

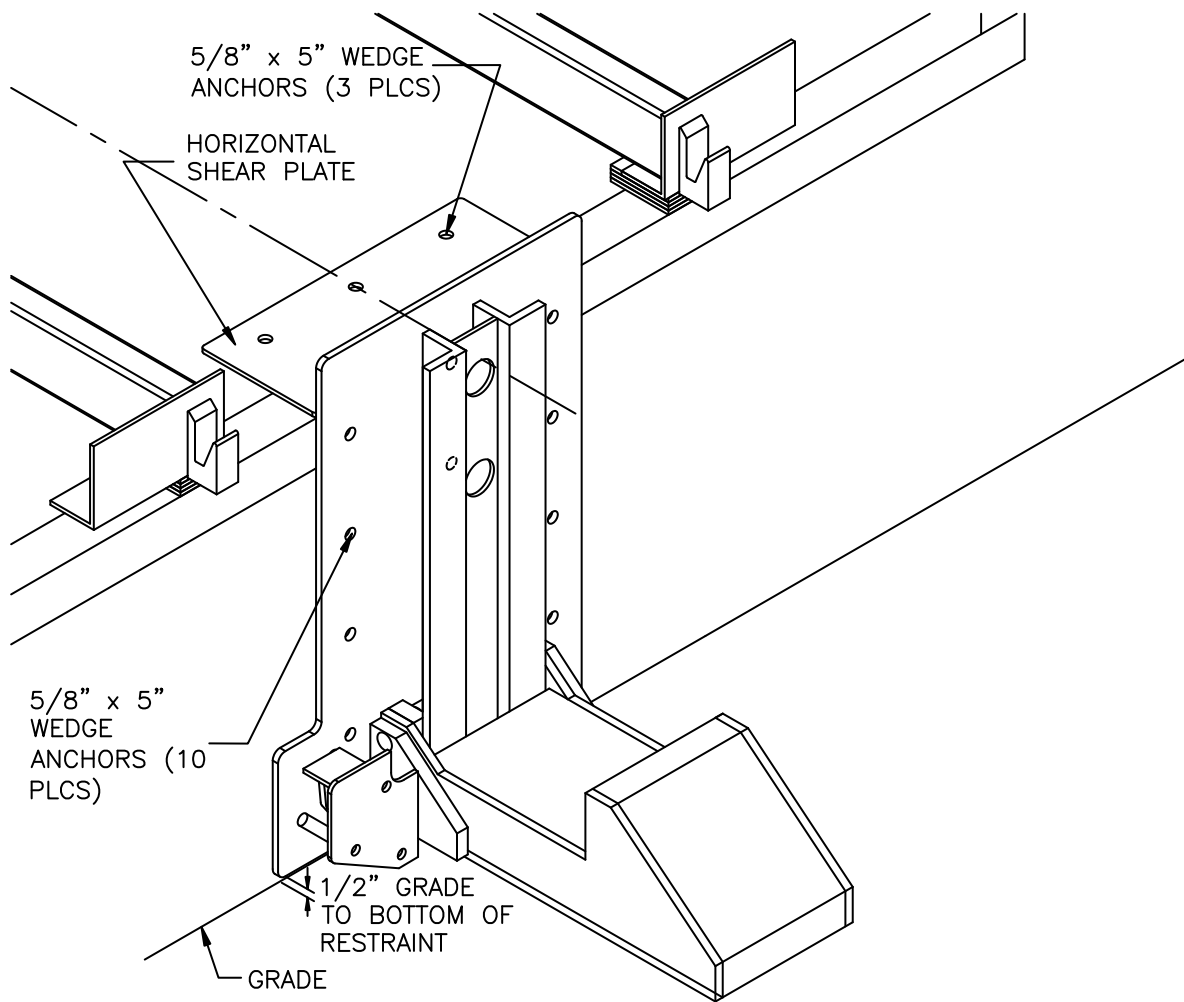

The following installation materials are included with the restraint:

- | | |
|-----------|----------------------------------|
| 13 pieces | 5/8" x 5" concrete wedge anchors |
| 1 piece | horizontal shear plate |

All other materials required are to be provided by the installer.

Mounting Requirements

1. The dock face on which the TRUCK-LOCK is to be mounted must be flat and vertically plumb for correct operation. If the dock face is not flat, it may be necessary to use shims behind the backplate of the restraint or to modify the dock face to provide a flat mounting surface. If shimming is required, it is necessary to place shims at all of the anchor hole locations where the backplate does not contact the wall. This will prevent distortion of the backplate when the anchors are tightened.
2. The TRUCK-STOP vehicle restraint requires a 4" bumper projection from the front of the bumper to the rear of the back plate of the restraint. Less than 4" of projection can allow trailer ICC bars to damage the restraint.
3. Some types of dock levelers that use lip saddles may interfere with the TRUCK-LOCK vehicle restraint. Depending upon the lip length, dock height, bumper projection, use of standoffs etc., modification to the restraint and/or dock leveler may be required. Consult the factory for specific applications.
4. The standard concrete anchors (5/8" x 5" wedge style) provided with this restraint may only be used on docks constructed of solid concrete. Docks constructed of other materials require special mounting considerations. Contact your local Nordock distributor for application specific information.
5. A 3/8" gap is required between the dock leveler front angle and the pit floor for installation of the horizontal shear plate.
6. Do not install the TRUCK-LOCK anchor bolts into concrete of questionable integrity.
7. If the driveway beneath the TRUCK-LOCK is affected by frost, additional clearance between the TRUCK-LOCK and the driveway may be required to prevent damage due to heaving.

Tools Required

- Welder
- Hammer drill with 5/8" diameter masonry bit
- 15/16" wrench
- General hand tools
- Touch up paint (Silver)
- Torque wrench (100 ft-lbs. min.)

Installation with Pit Type Levelers

1. Place barricades around pit on dock floor and driveway while installing the TRUCK-LOCK.
2. The horizontal shear plate **MUST BE INSTALLED** to achieve the full rated restraining capacity of the TRUCK-LOCK.

The installation method for the horizontal shear plate will depend upon the height of the front curb steel off grade and if there is a sufficient gap under the dock leveler front angle.

The diagrams below illustrate acceptable shear plate mounting methods for the most common types of restraint installations.

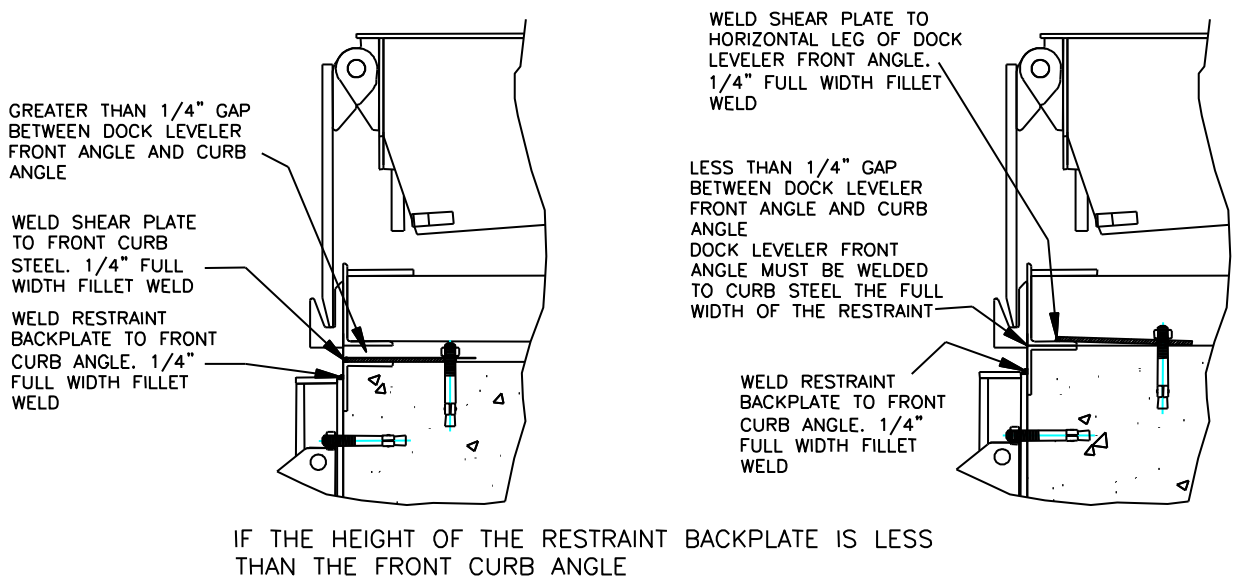
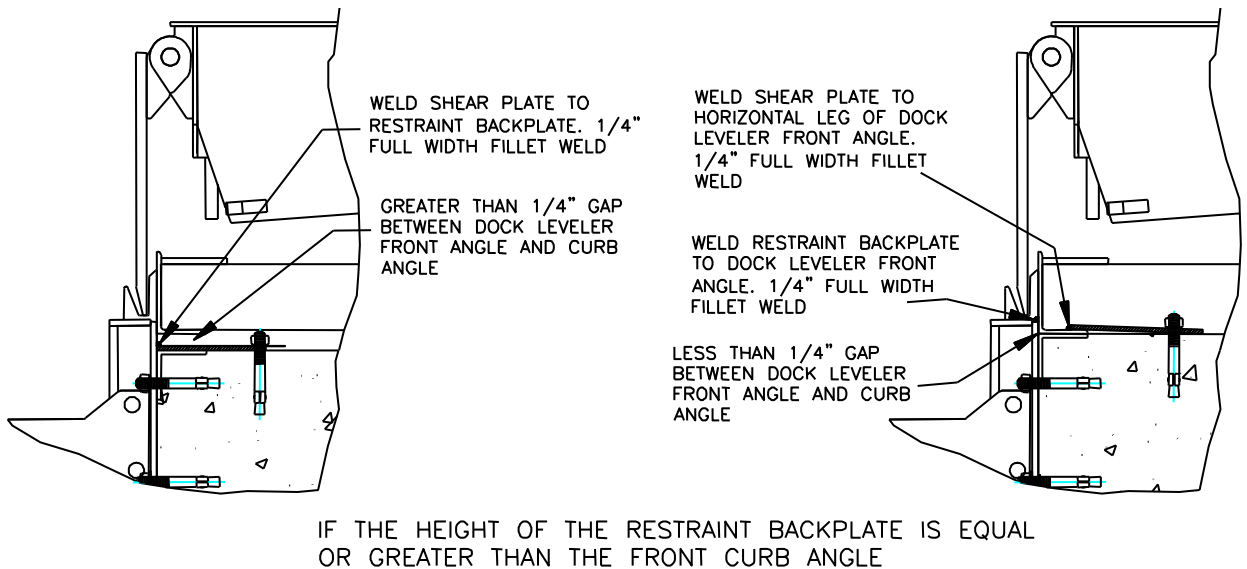

Please consult the factory if your particular site conditions prohibit installation of the shear plate using the above methods.



WARNING

ALWAYS USE DOCK LEVELER SUPPORT WHEN WORKING UNDER A DOCK LEVELER RAMP OR LIP

3. If there is sufficient clearance, insert the horizontal shear plate into the gap between the dock leveler front angle and the pit floor.

Otherwise use one of the methods illustrated on the previous page.

4. Place the bottom of the TRUCK-LOCK $\frac{1}{2}$ " above the driveway and centre it with the dock leveler pit.
 - a. If the horizontal shear plate is above the top of the backplate, weld the full width of the shear plate to the dock leveler front angle. If there is no dock leveler front angle (clean frame design), weld the full width of the shear plate to the front pit curb angle.
 - b. If the horizontal shear plate is level with or below the top of the backplate, tack the shear plate to the backplate at both ends. Pull the restraint and shear plate away from the dock and weld the full width of the plate on the topside using a $\frac{1}{4}$ " fillet. Refer to adjacent diagram.

Paint welded areas to prevent rust.

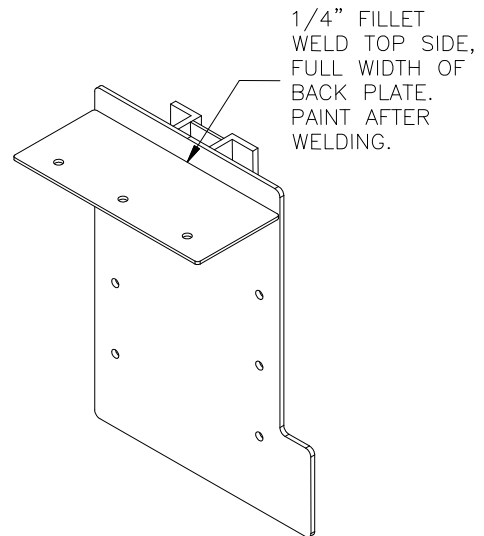

5. Slide the TRUCK-LOCK and shear plate back into position.
6. Before anchoring the TRUCK-LOCK, operate the dock leveler through its full range of motion.
 - a. Check that the TRUCK-LOCK does not interfere with the below dock operation and that the dock leveler lip does not come to rest on the TRUCK-LOCK in such a way that it supports the weight of the dock leveler.
 - b. In the full below dock position, check that the pendant dock leveler lip does not project beyond the face of the bumpers when it is resting on the top of the restraint.



WARNING

Improper installation that allows the pendant dock leveler lip to support the weight of the dock leveler could result in serious injury or death. It is sometimes necessary to

install lip deflector plates to prevent the possibility of the pendant lip storing on top of or behind the restraint backplate.

This restraint is provided with a removable deflector plate shown in the diagram below. If the supplied deflector is insufficient to prevent the dock leveler lip from resting on top of or in behind the restraint, the installer must provide additional steel.

If the supplied deflector plate interferes with the storing of the dock leveler lip, it may be removed.

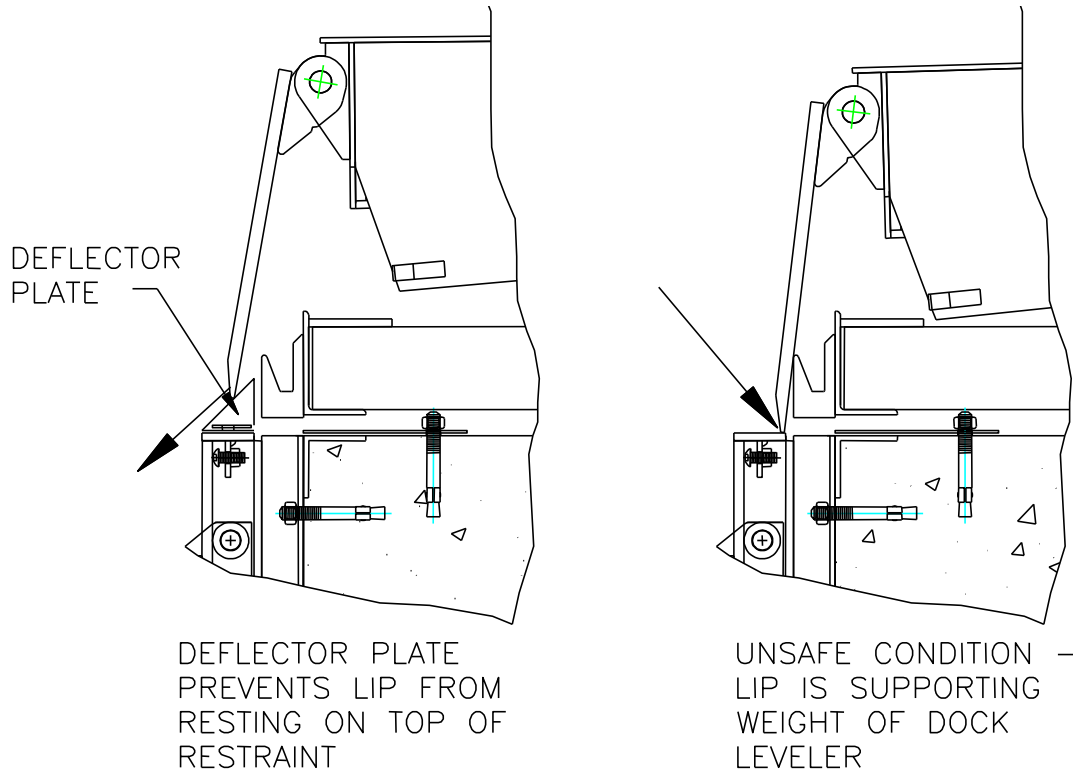

- Anchor the TRUCK-LOCK backplate to the dock face using the anchors provided. The anchor bolts must be torqued to 90 ft-lbf to achieve maximum holding strength.

NOTE

Anchors must be installed in a minimum of six (6) back plate mounting holes. The anchors should be installed as the holes are drilled to prevent the TRUCK-LOCK from shifting.

- Anchor the shear plate to the pit floor using the concrete anchors provided. The anchor bolts must be torqued to 90 ft-lbf to achieve maximum holding strength.
- Mount the “CAUTION, Enter or Leave...” sign provided to the exterior wall as shown in the diagram on the next page.

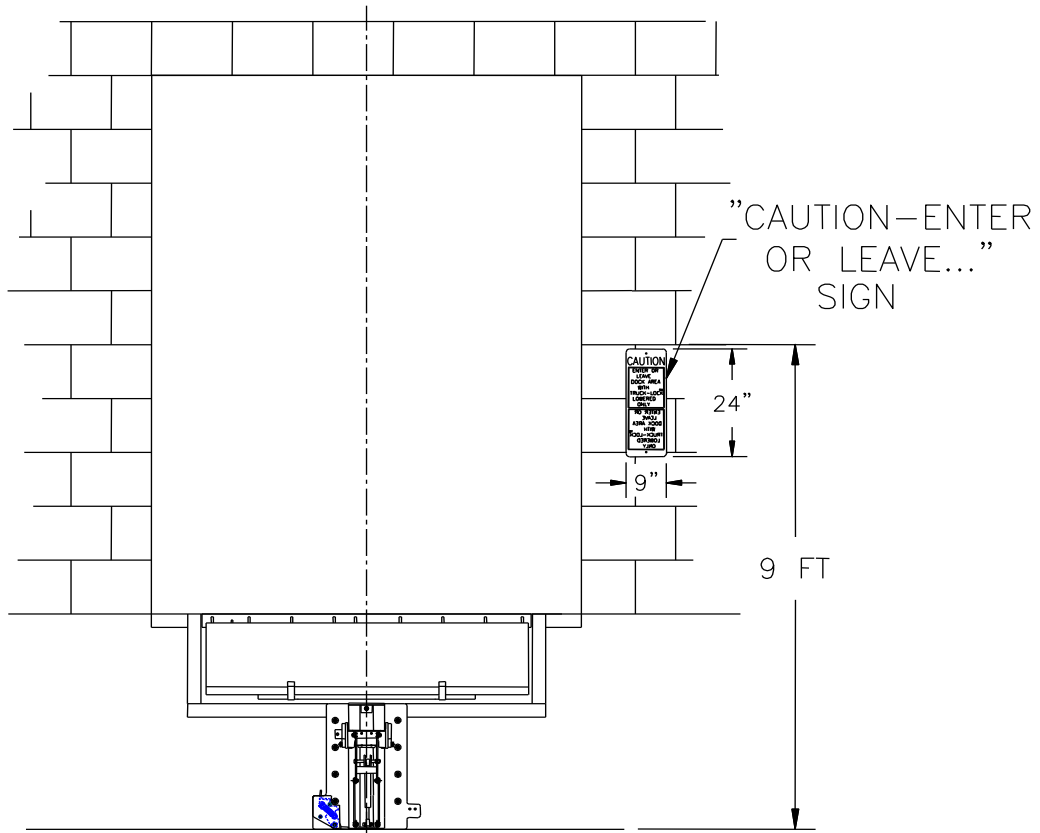

10. Mount the hanger bracket for the push bar to the inside building wall.
11. Mount the Operating Instruction Placard on the inside wall, in an easy to read place near the push bar hanger bracket and dock.
12. Instruct the dock workers how to correctly use the TRUCK-LOCK. The Operating Procedure can be found in the next section.

Installation of Optional Driveway Mounting Plate

When the optional driveway mounting plate is used, the driveway material must be concrete. For driveway materials other than concrete, a stepped concrete pad must be poured as shown next page. Allow concrete to properly cure before installing restraint.

Place plate on driveway or concrete pad.

Place bottom of TRUCK-LOCK on the driveway plate. Keep both the TRUCK-LOCK and driveway plate centered with the dockleveler pit.

Make sure the horizontal shear plate is welded to the restraint back plate as previously noted in Installation Instruction 4a and b.

Weld the bottom of the TRUCK-LOCK back plate to the driveway plate, as shown on next page. Paint welded areas to prevent rust.

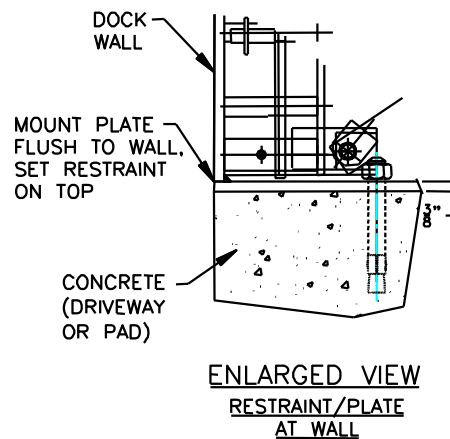
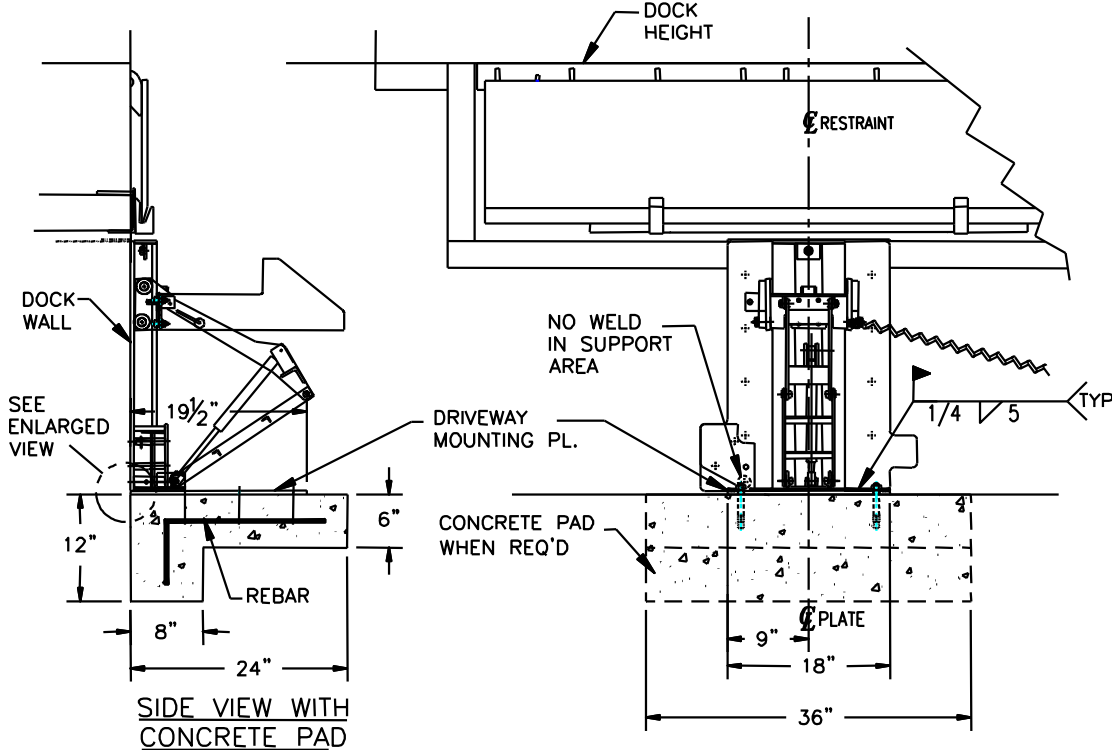

Operation Procedure



WARNING

Before operating or maintaining this truck restraint, read and follow the safety practices contained in this manual. Failure to follow the guidelines in this manual and those in effect in the workplace can result in serious bodily harm and equipment damage.

Do not load or unload any truck unless you make certain the TRUCK-LOCK has securely engaged the truck's ICC bar and that the truck brakes are set. If the TRUCK-LOCK does not engage the truck's ICC bar for whatever reason, THE TRUCK'S WHEELS MUST BE CHOCKED BEFORE LOADING OR UNLOADING CAN BEGIN.

Failure to store the TRUCK-LOCK when not in use could result in damage to the TRUCK-LOCK and incoming trucks.

To Hitch Truck:

1. Position truck against dock bumpers and set brakes.
2. Using the pushbar provided with the TRUCK-LOCK, push the latch lever down. The hook will rise to engage the truck's ICC bar.
3. If the truck cannot be hitched, chock the trailer wheels and make certain that the brakes are set.

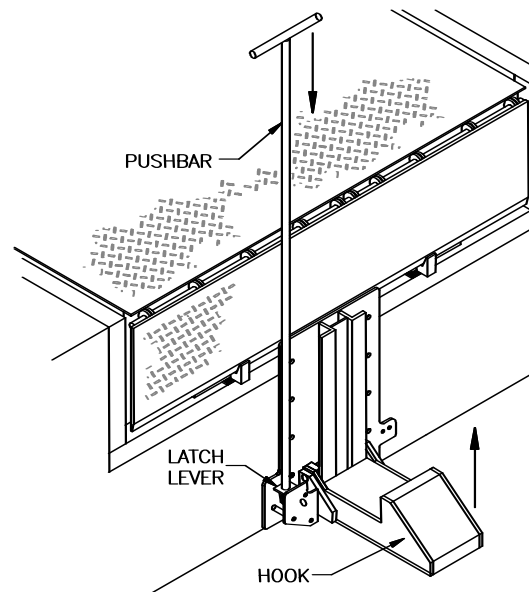

To Release Truck:

1. Using pushbar, press the hook down until it latches. Push straight down in the centre at the rear of the hook as shown in the diagram.
2. The truck may now pull out.

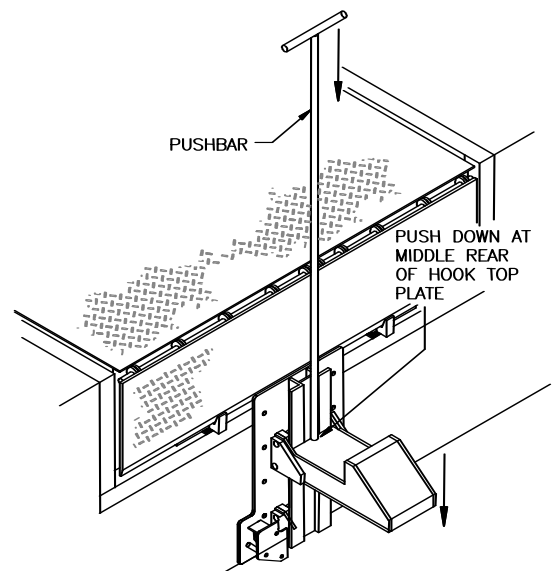

Maintenance Schedule

⚠ WARNING

Before servicing this restraint, read and follow the safety practices contained in this manual. Failure to follow the guidelines in this manual and those in effect in the workplace can result in serious bodily harm and equipment damage.

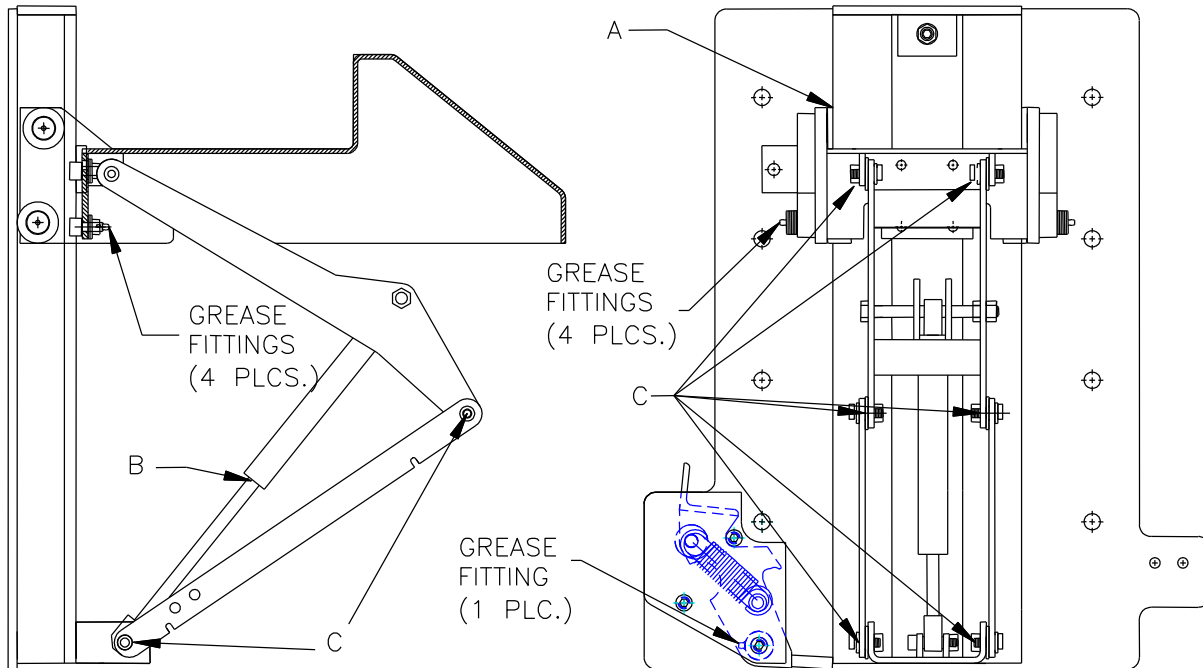

Item	Lubrication	Inspection	Cleaning
Grease Fittings (9 locations)	Every 90 days Using MP grease	None	Remove debris as required
- A - Track & Rollers	None required	Weekly – Check for bent track or damaged rollers	Remove debris as required
- B - Gas Spring	None required	Monthly – Check for oil leaks	Remove debris from rod as required
- C - Pivot Points (7 locations)	None required	Monthly – Check for loose fasteners - Tighten as required	Remove debris as required
Driveway area around restraint	None required	None	As required to remove debris
Concrete Anchors (11 locations)	None required	Weekly - Check that all anchors are tight. Re-tighten if necessary	None required

Parts Replacement



WARNING

Before servicing this restraint, read and follow the safety practices contained in this manual. Failure to follow the guidelines in this manual and those in effect in the workplace can result in serious bodily harm and equipment damage.

NOTE

The gas spring is partially compressed when the restraint stop plate is installed. To avoid pinching fingers or other body parts, use caution when removing the stop plate.

Removing Hook From Track

If the hook has to be removed to replace damaged or worn parts, the following procedure must be used to avoid personal injury.

1. Store hook.
2. Unscrew retaining bolt from front of track and remove stop plate.
3. Apply weight to the hook and release the latch.
4. Allow the hook to rise slowly to the top of the track.
5. Block up the restraint hook to support its weight when the gas spring is removed.
6. Remove the nut from the 5 1/2 " long bolt and slide the bolt out, also removing the jam nut. Remove bolt completely.

NOTE

The gas spring should come apart easily using only moderate hand pressure. Do not use a pry bar on the rod as it may damage the surface causing premature failure of the gas spring.

7. Once the gas spring is removed, the hook can be lifted out of the track and lowered to the ground in front of the backplate without disconnecting any of the linkages.

Re-installing Hook Into Track

1. Lower hook back into track and block up at a height so that the gas spring may be re-installed easily.
2. Position the cylinder end block between the mounting brackets and insert the 5 1/2" long bolt from the left side of arm assembly. Replace the jam nut on the inside of the right tension arm and nylock nut on the outside of the tension arm.
3. Apply weight to hook to lower it into the latched stored position.
4. Re-install stop plate and retaining bolt.

Parts List

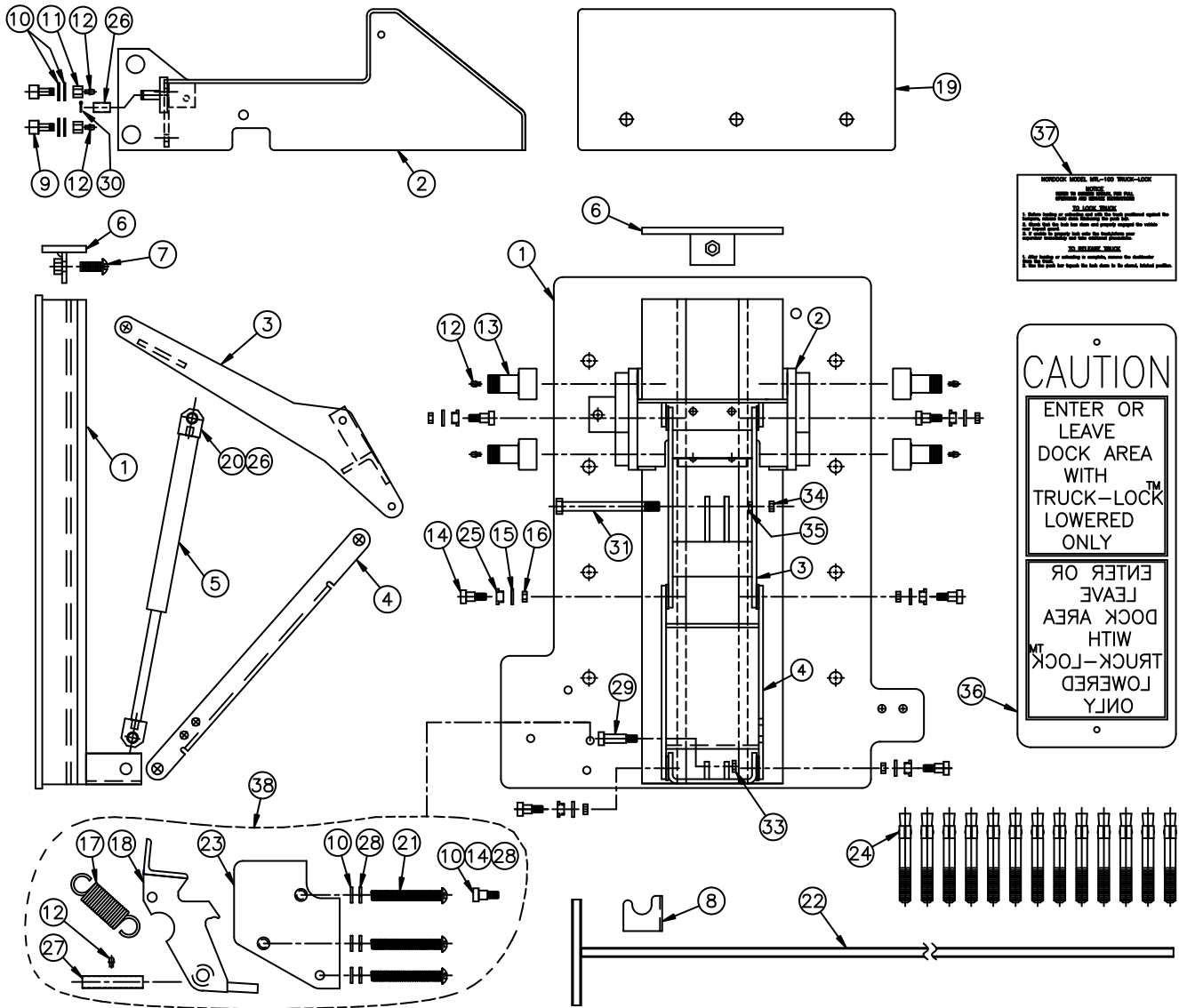

Item	Qty	Description / Model	P/N	Note
1	1	Back Plate Weldment	52-0158	
2	1	Hook Weldment	52-0102	
3	1	Triangle Arm Weldment	52-0157	
4	1	Tension Arm	53-0123	
5	1	Gas Spring, MTL Series Restraint (Rod End Down)	Gas Spring only..... C/w end blocks (Pt 20) and bushings (Pt 26)...	53-0164 52-0166
6	1	Stop Plate Weldment	52-0106	
7	1	Bolt, Button Head, 1/2" x 1 1/2" Stainless Steel	13-0966	
8	1	Push Bar Hanger Bracket	53-0110	
9	4	Bearing Cam Follower, Ø3/4"	13-0915	
10	12	Washer, 3/8" SAE, ZP	13-0203	
11	4	Nut, 3/8"-24 x 1/2" Nylock, ZP	13-0969	
12	9	Grease Fitting, 3/16", Drive-in	13-0655	

Item	Qty	Description / Model	P/N	Note
13	4	Bearing, Cam Follower, Ø 1-3/4", Heavy Stud	13-0916	
14	7	Bolt, Shoulder, 1/2" x 1/2", ZP	13-0965	
15	6	Washer, Flat, 1/2", STD, ZP	13-0267	
16	6	Nut, Hex, Jam, Nylock 3/8"-16	13-1331	
17	1	Extension Spring, 0.148" Wire, 4-1/2" FL	23-0441	
18	1	Latch Plate Weldment	52-0107	
20	2	Cylinder End Block	C3-0118	
21	3	Bolt, SHCS 3/8 x 4 1/4" long	13-1482	
22	1	Push Bar Weldment	52-0108	
23	1	Latch Cover Plate	53-0181	
24	13	Anchor, Concrete, Wedge, Ø5/8" x 5", ZP	13-0779	
25	6	Bushing, Flange, 1/2" ID x 5/8" OD x 3/8", Oilite	13-0953	
26	3	Bushing, Oilite, 1/2"ID x 5/8"OD x 3/4"Long	13-0963	
27	3	Pipe Spacer, 3/8" Schedule 80	53-0144	
28	4	Washer, 3/8" Lock, Grade 5	13-0767	
29	1	Shoulder Bolt, 1/2" x 1 1/4" long, 3/8" thread	13-1365	
30	1	Cotter Pin, 1/8" x 1" long	13-0171	
31	1	Bolt, 1/2" x 5 1/2" long, plated	13-1638	
33	1	Jam Nut, 3/8", plated	13-1021	
34	1	Nut, Nylock, 1/2", plated	13-0750	
35	1	Jam Nut, 1/2", plated	13-1639	
36	1	Caution Sign, Outside	53-0127	
37	1	Operating Instruction Placard	53-0126	
38	1	Latch Assembly complete (Pts 10,12,14,17,18,23,27,28)	52-0114	