

**TRUCK-LOCK™ SERIES**  
**MTL-250**

**Low Profile**  
**Vehicle Restraint Manual**

**Owner's Manual**

This manual applies to MTL-250 series restraints manufactured after 2013/06/01 with serial numbers 25005 and greater.

**P/N: 59-0008-F**

***NORDOCK INC.***

Website: [nordockinc.com](http://nordockinc.com) ~ Email: [sales@nordockinc.com](mailto:sales@nordockinc.com) ~ Toll free: 866-885-4276  
Nordock Inc. reserves the right to make changes to specifications without notice or obligation. Nordock products may be covered by various U.S. and foreign patents or pending applications.



# Contents

Contents .....	2
Preface .....	3
Problems, Errors and Omissions .....	3
Restraint Identification .....	3
Copyright .....	3
Warranty .....	4
Safety Practices .....	5
Labels .....	6
Installation .....	7
Tools Required .....	8
Mounting Requirements.....	8
Installation with Pit Type Levelers.....	9
Dock Leveler Interconnect .....	14
Installation of Optional Driveway Mounting Plate.....	14
Operation .....	16
To Hitch Truck: .....	16
To Release Truck: .....	16
Troubleshooting .....	17
Maintenance Schedule.....	18
Parts Replacement.....	19
Re-installing Hook Into Track.....	19
Wiring Diagram.....	20
Parts List .....	21

# Preface

## PLEASE READ AND UNDERSTAND THIS MANUAL COMPLETELY

This manual gives detailed information and instruction on how to operate and maintain your equipment correctly. Failure to do so could result in personal injury, and/or equipment damage. Please consider this manual a permanent part of the unit and keep it near the restraint for reference whenever needed.

If you have any questions about this manual, the restraint, its components, or our products and services, please call us at 1-866-885-4276 and we will be happy to assist you. With proper care and maintenance, this restraint is designed to work effectively and efficiently for many years to come.

## Problems, Errors and Omissions

This manual has been prepared with the utmost care and attention to detail to provide accurate parts and service information should the need arise. Nordock Incorporated believes this manual will provide the operators of this restraint all the necessary information required to operate and maintain it for many years. If you believe there is an error, if you have a problem following the guidelines, or if there is information that you feel is missing from this manual, please contact us at the above number so that we may resolve the issue immediately.

## Restraint Identification

It is very important that in order to obtain the best possible service from Nordock Inc., please provide the model and serial number of the restraint whenever you contact us. Below is the same serial number decal that will be found on the left hand hook side plate (standing outside facing the restraint). Please record the information from the decal on the restraint in the area below. This will greatly reduce the possibility of improper parts being shipped to you.

	Phone 866-885-4276 www.nordockinc.com
Model:	<input type="text"/>
Capacity:	<input type="text"/>
<small>Product may be covered by various U.S. and foreign patents or pending applications</small>	



## Copyright

This manual is copyright to Nordock Incorporated. All information, text, drawings, and technical data contained herein are for reference only. No part of this manual may be copied, altered, or stored on electronic media, and cannot be revealed to others for the purpose of competition.

# Warranty

Nordock Incorporated expressly warrants that all of its manufactured product shall remain free of defects in material and workmanship under normal use for a period of one-year from the date of delivery to the purchaser. The purchaser must maintain and operate the product in accordance with proper procedures. In the event the product proves defective in material or workmanship, Nordock Inc. will, at its option, either:

1. replace the product or the defective portion thereof without charge to the purchaser; or,
2. alter or repair the product on site or elsewhere, as Nordock Inc. may deem advisable, without charge to the purchaser.

The warranty stated herein is that offered by Nordock Inc. and expressly disclaims all implied warranties including those of merchantability and fitness. This warranty does not cover any failure caused by improper installation, misapplication, overloading, abuse, negligence, or failure to maintain and protect the equipment from vehicle impact. Nordock Inc. or its representative assume no responsibility or liability for any incidental or consequential damages of any kind including loss of use of any equipment, damage or failure resulting from the use of unauthorized replacement parts or equipment modification, or damages resulting from the misuse of the equipment.

Nordock Inc. warranties extend only to the product itself. Nordock Inc. disclaims all liability of any kind arising out of the workmanship, methods and materials used by the installer or premature product wear, product failure, property damage or bodily injury arising from improper installation.

These warranties as stated herein are the exclusive remedies for all claims.

# Safety Practices

The operators of this unit must read these safety practices before installing, operating or servicing the TRUCK-LOCK™. Failure to follow these safety practices may result in bodily injury, property damage or death.



## WARNING

READ AND FOLLOW THE OPERATING INSTRUCTIONS CONTAINED IN THIS MANUAL BEFORE OPERATING THE TRUCK-LOCK™. If you do not understand the instructions, contact your supervisor for explanation and instruction on the safe operation of this unit.

Improper installation of the TRUCK-LOCK™ could result in serious injury or death to dock workers or other users of the restraint.

The following guidelines are to be used in conjunction with all laws, governances and codes in effect where the TRUCK-LOCK™ is installed.

1. Use by untrained people can cause property damage, serious injury and/or death. Your supervisor should instruct you on the safe and proper way to use the TRUCK-LOCK. Read and follow the complete OPERATING procedure on page 14 before use.
2. DO NOT USE THE TRUCK-LOCK IF IT IS NOT WORKING RIGHT. Tell your supervisor it needs repair.
3. Be certain all people in the driveway stand clear when the TRUCK-LOCK is being operated.
4. Do not stand in the driveway between the dock and a backing truck.
5. Keep all body parts clear of restraint guide tracks and moving parts at all times.
6. Do not install the TRUCK-LOCK anchor bolts into concrete of questionable integrity.
7. Do not load or unload any truck until you make certain that the TRUCK-LOCK has securely engaged the truck's ICC bar and the brakes are set. If the TRUCK-LOCK does not hitch the truck's ICC bar for any reason, BE CERTAIN TO CHOCK THE TRUCK WHEELS BEFORE PROCEEDING WITH LOADING OR UNLOADING.
8. Do not use the TRUCK-LOCK as a step.
9. All electrical troubleshooting and repair must be done by a qualified technician and must meet all applicable codes. Before doing any electrical work, make certain the power is disconnected and properly tagged or locked out.

10. If the TRUCK-LOCK fails to operate using the procedures contained in this manual, do not use the TRUCK-LOCK. Contact Nordock Inc. or an authorized service representative for service.
11. Whenever any maintenance or repair is to be performed on the restraint, barricade the area around the dock floor and driveway and place clear signage on the perimeter that the dock and restraint are not to be operated.
12. If you have any questions, contact your supervisor or your local Nordock Incorporated representative.

## Labels

The labels and decals on the TRUCK-LOCK must be kept in clean, legible condition at all times. The diagram below shows the decals and their placement on the restraint. Please check their condition on a daily basis, and replace them immediately if they become unreadable.

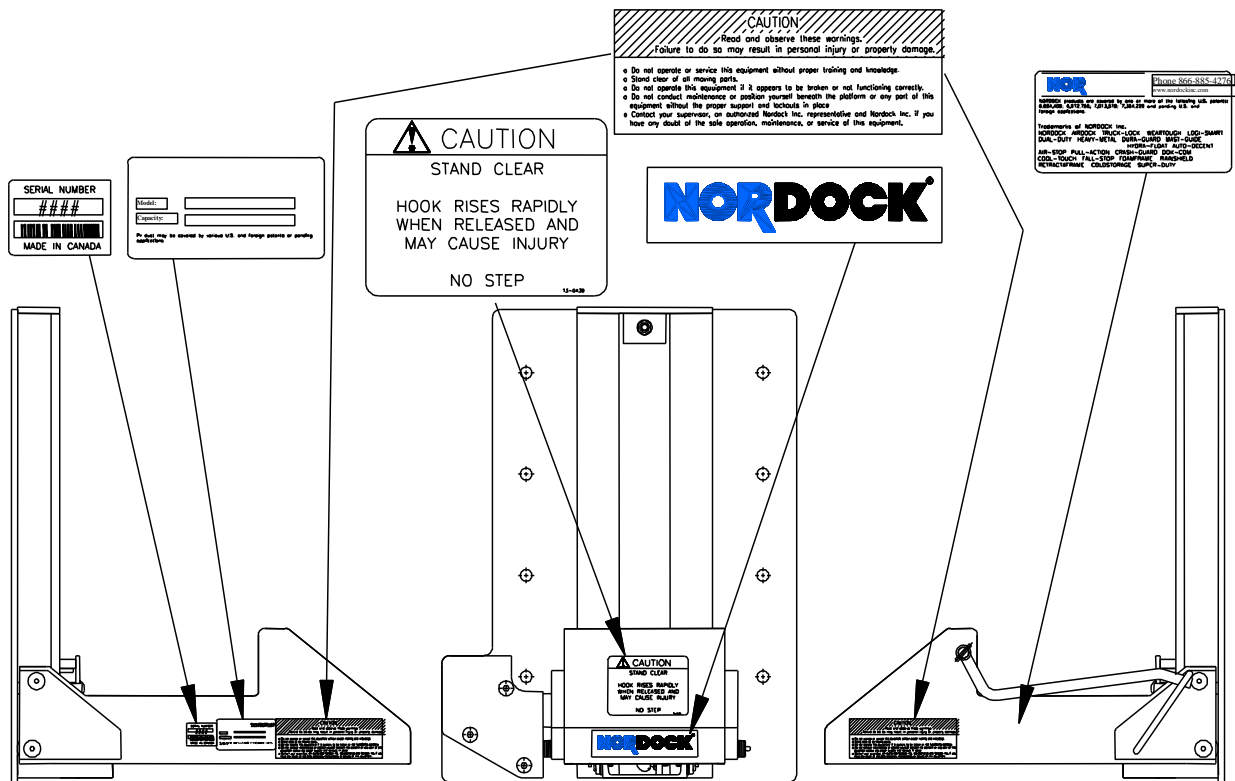

# Installation

## **WARNING**

IMPROPER INSTALLATION OF THIS TRUCK-LOCK COULD RESULT IN SERIOUS INJURY OR DEATH TO DOCK WORKERS OR OTHER RESTRAINT USERS

A typical TRUCK-LOCK restraint installation is shown below:

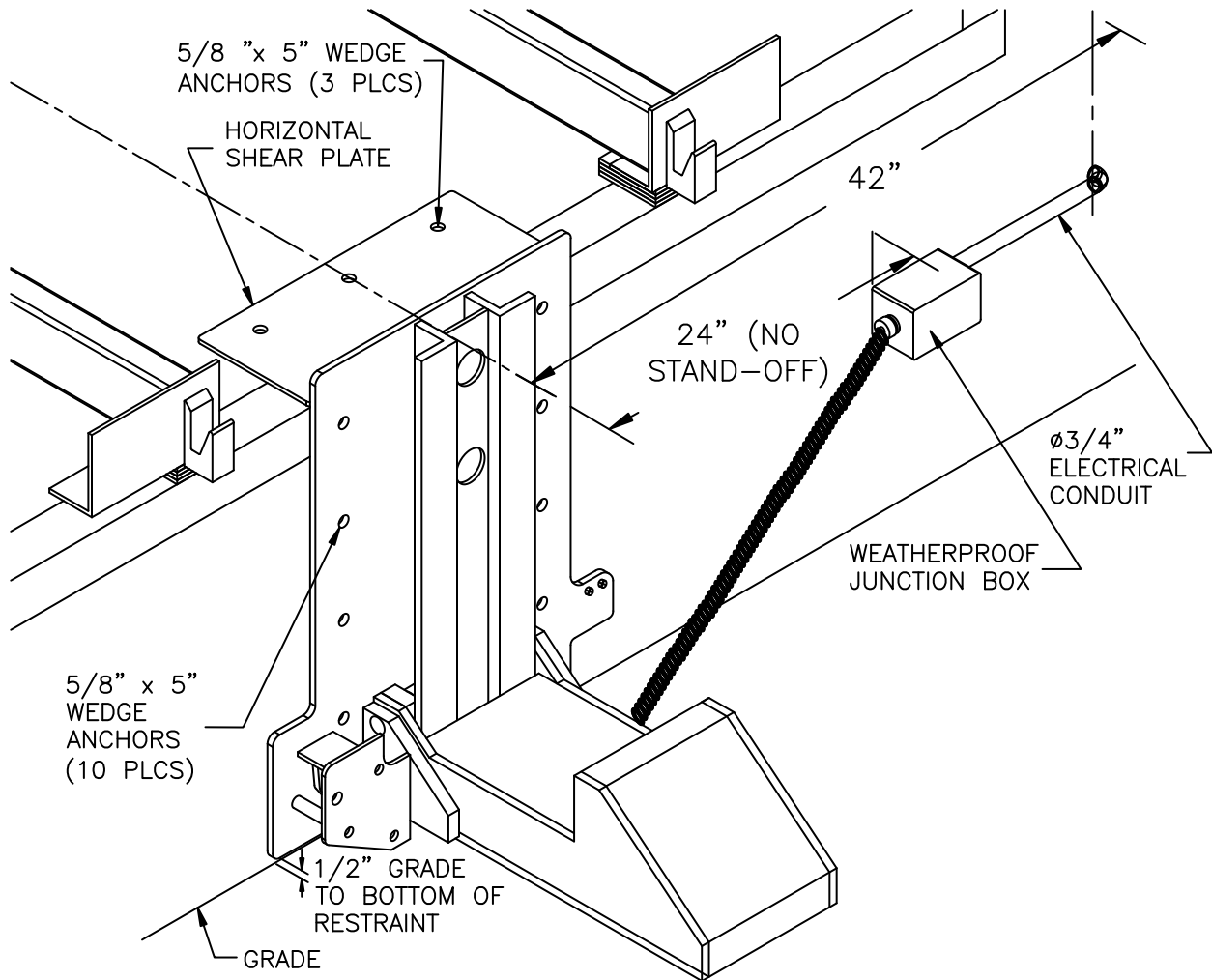

The following installation materials are included with the restraint:

- 13 pcs. 5/8" x 5" concrete wedge anchors
- 1 pc horizontal shear plate
- 1 pc pre-wired weatherproof junction box

All other materials required are to be provided by the installer.



## **Tools Required**

- Welder
- Hammer drill with 5/8" diameter masonry bit
- 15/16" wrench
- General hand tools
- Touch up paint (Silver)
- Torque wrench (100 ft-lbs. min.)

## **Mounting Requirements**

1. The dock face on which the TRUCK-LOCK is to be mounted must be flat and vertically plumb for correct operation. If the dock face is not flat, it may be necessary to use shims behind the backplate of the restraint or to modify the dock face to provide a flat mounting surface. If shimming is required, it is necessary to place shims at all of the anchor hole locations where the backplate does not contact the wall. This will prevent distortion of the backplate when the anchors are tightened.
2. The TRUCK-LOCK vehicle restraint requires a 4" bumper projection from the front of the bumper to the rear of the back plate of the restraint. Less than 4" of projection can allow trailer ICC bars to damage the restraint.
3. Some types of dock levelers that use lip saddles may interfere with the TRUCK-LOCK vehicle restraint. Depending upon the lip length, dock height, bumper projection, use of standoffs etc., modification to the restraint and/or dock leveler may be required. Consult the factory for specific applications.
4. The standard concrete anchors (5/8" x 5" wedge style) provided with this restraint may only be used on docks constructed of solid concrete. Docks constructed of other materials require special mounting considerations. Contact your local Nordock distributor for application specific information.
5. A 3/8" gap is required between the dock leveler front angle and the pit floor for installation of the horizontal shear plate.
6. Do not install the TRUCK-LOCK anchor bolts into concrete of questionable integrity.
7. If the driveway beneath the TRUCK-LOCK is affected by frost, additional clearance between the TRUCK-LOCK and the driveway may be required to prevent damage due to heaving.
8. When the optional driveway mounting plate is used the driveway material must be concrete. See Installation of Optional Driveway Mounting Plate section of this manual.

## Installation with Pit Type Levelers

1. Place barricades around pit on dock floor and driveway while installing the TRUCK-LOCK.
2. The horizontal shear plate **MUST BE INSTALLED** to achieve the full rated restraining capacity of the TRUCK-LOCK.

The installation method for the horizontal shear plate will depend upon the height of the front curb steel off grade and if there is a sufficient gap under the dock leveler front angle.

The diagrams below illustrate acceptable shear plate mounting methods for the most common types of restraint installations.

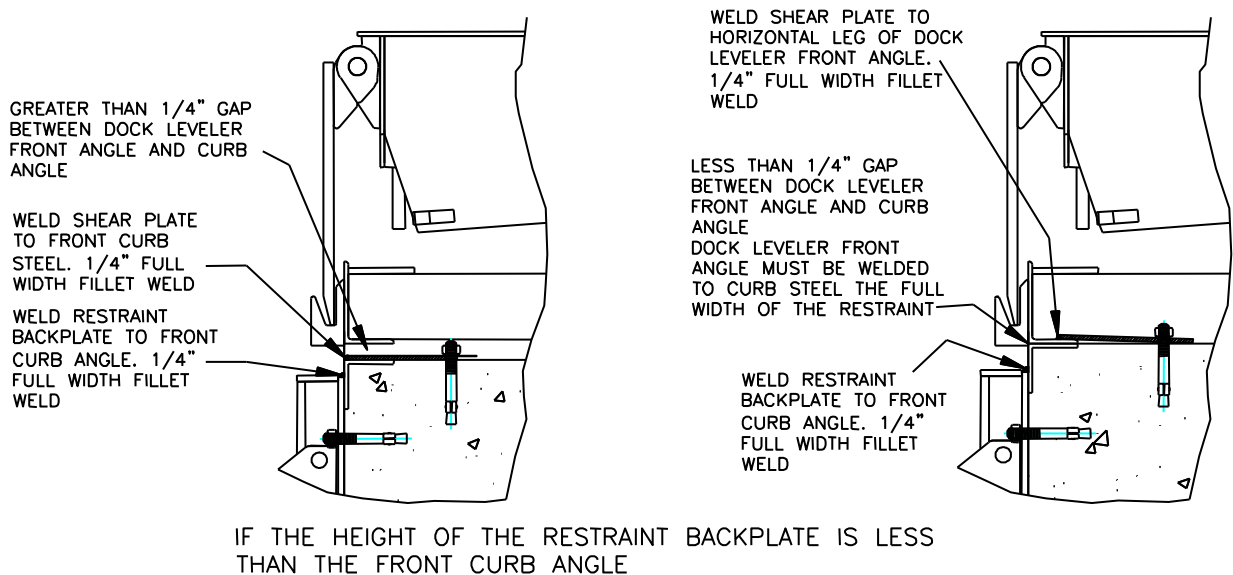
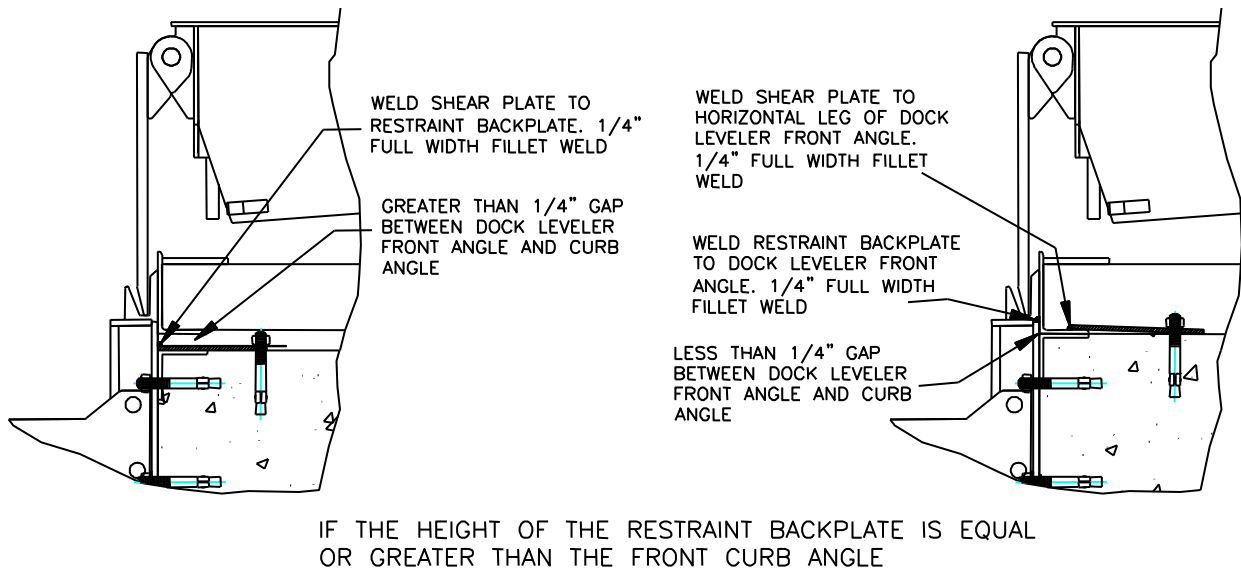

Please consult the factory if your particular site conditions prohibit installation of the shear plate using the above methods.



## WARNING

ALWAYS USE DOCK LEVELER SUPPORT WHEN WORKING UNDER A DOCK LEVELER RAMP OR LIP

3. If there is sufficient clearance, insert the horizontal shear plate into the gap between the dock leveler front angle and the pit floor.

Otherwise use one of the methods illustrated on the previous page.

4. When optional driveway mounting plate is required, refer to the Installation of Optional Driveway Mounting Plate section of this manual.
5. Place the bottom of the TRUCK-LOCK  $\frac{1}{2}$ " above the driveway and centre it with the dock leveler pit.

- a. If the horizontal shear plate is above the top of the backplate, weld the full width of the shear plate to the dock leveler front angle. If there is no dock leveler front angle (clean frame design), weld the full width of the shear plate to the front pit curb angle.
- b. If the horizontal shear plate is level with or below the top of the backplate, tack the shear plate to the backplate at both ends. Pull the restraint and shear plate away from the dock and weld the full width of the plate on the topside using a  $\frac{1}{4}$ " fillet. Refer to adjacent diagram.

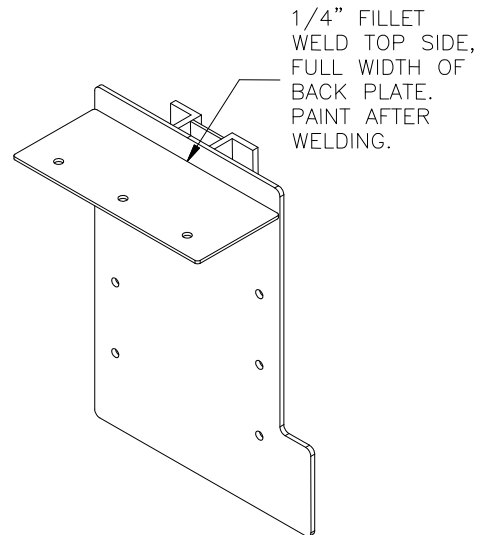

Paint welded areas to prevent rust.

6. Slide the TRUCK-LOCK and shear plate back into position.
7. Before anchoring the TRUCK-LOCK, operate the dock leveler through its full range of motion.
  - a. Check that the TRUCK-LOCK does not interfere with the below dock operation and that the dock leveler lip does not come to rest on the TRUCK-LOCK in such a way that it supports the weight of the dock leveler.
  - b. In the full below dock position, check that the pendant dock leveler lip does not project beyond the face of the bumpers when it is resting on the top of the restraint.



## WARNING

Improper installation that allows the pendant dock leveler lip to support the weight of the dock leveler could result in serious injury or death. It is sometimes necessary to install lip deflector plates to prevent the possibility of the pendant lip storing on top of or behind the restraint backplate.

This restraint is provided with a removable deflector plate shown in the diagram below. If the supplied deflector is insufficient to prevent the dock leveler lip from resting on top of or in behind the restraint, the installer must provide additional steel.

If the supplied deflector plate interferes with the storing of the dock leveler lip, it may be removed.

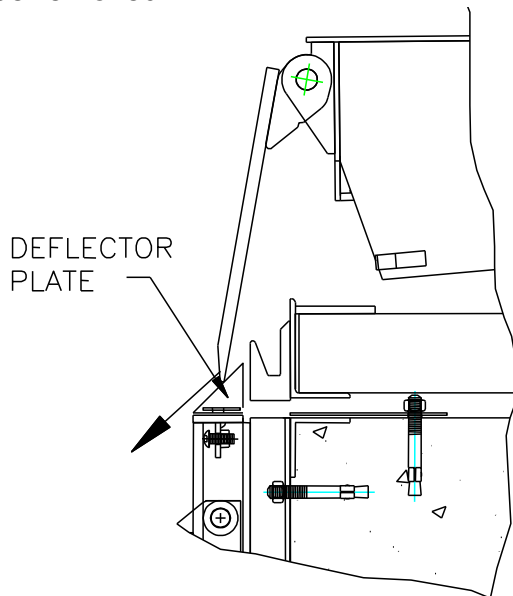

DEFLECTOR PLATE PREVENTS LIP FROM RESTING ON TOP OF RESTRAINT

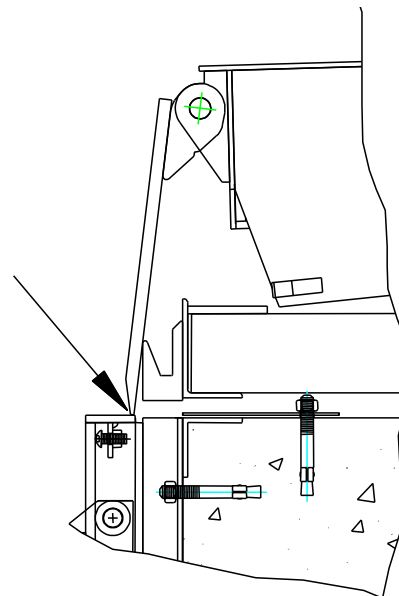

UNSAFE CONDITION — LIP IS SUPPORTING WEIGHT OF DOCK LEVELER

8. Anchor the TRUCK-LOCK backplate to the dock face using the anchors provided. The anchor bolts must be torqued to 90 ft-lbf to achieve maximum holding strength.

## NOTE

Anchors must be installed in a minimum of six (6) back plate mounting holes. The anchors should be installed as the holes are drilled to prevent the TRUCK-LOCK from shifting.

9. Anchor the shear plate to the pit floor using the concrete anchors provided. The anchor bolts must be torqued to 90 ft-lbf to achieve maximum holding strength.

**⚠ WARNING**

Before doing any electrical work, the power must be disconnected and properly locked/tagged off. Failure to do so could result in death or serious injury. All electrical work must meet all applicable codes and be carried out by a qualified technician.

**NOTE**

The control voltage for this restraint is 24 VDC. All motor power wires or other high voltage wires should be run in a separate conduit.

10. Mount the control box inside the building, to the left of the doorway, 4 ft. above the floor. Refer to diagram below

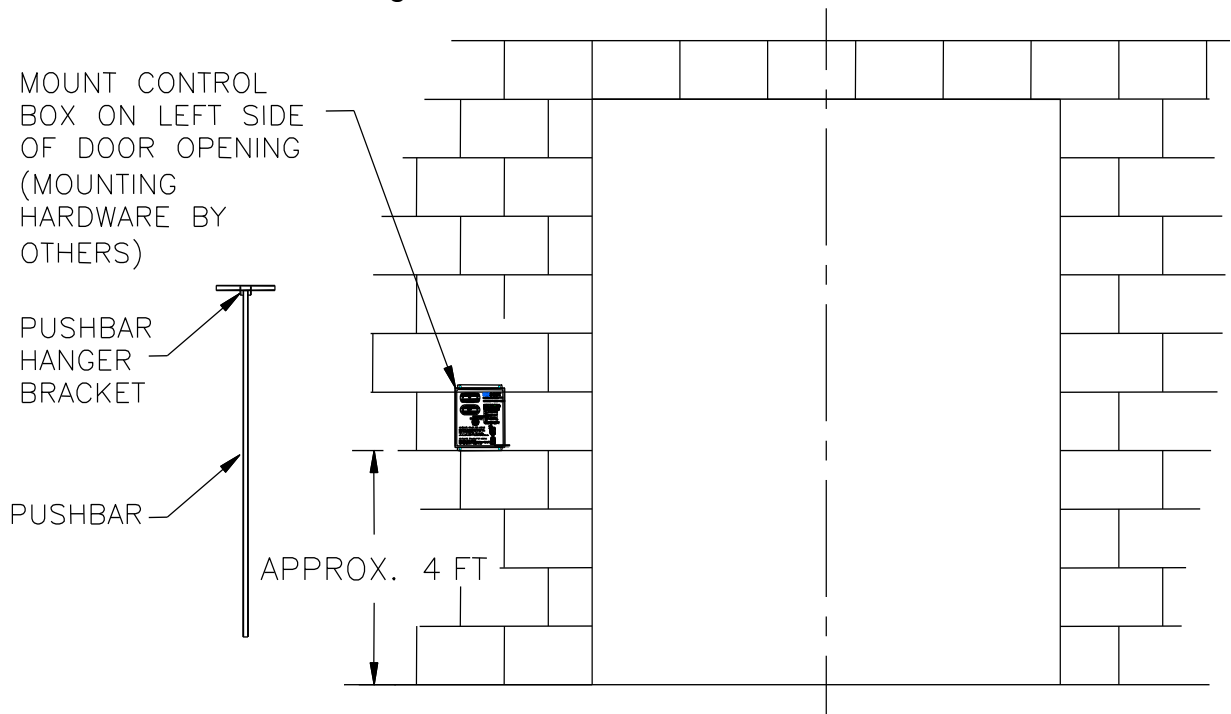

- 11. Mount the hanger bracket for the pushbar to the inside building wall.
- 12. The outside signal light is to be placed approximately 9 ft above the driveway on the driver's side of the door opening as shown in the diagram below. Drill a hole through the wall at the centre of the signal light mounting position.
- 13. Run a length of 16/3 electrical cable (not supplied) from the control box location through the wall. Make connections in panel and signal light assembly as indicated in the wiring diagram located at the back of this manual.

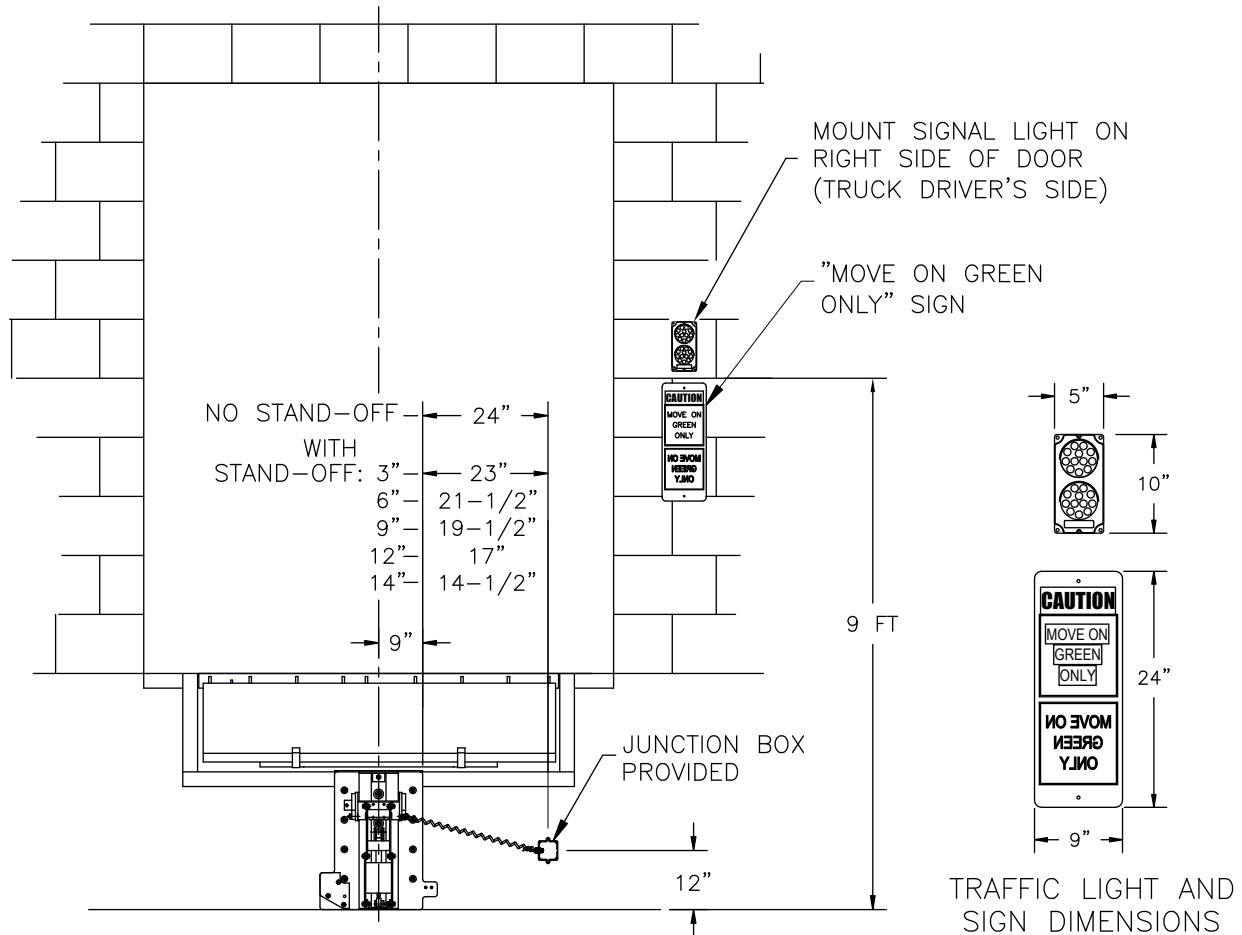

14. Fasten the signal light housing to the wall.
15. Mount the "Move On Green Only" sign provided to the exterior wall under the signal light as shown in the diagram above.
16. Mount the supplied electrical junction box to the exterior wall adjacent to the restraint in the location shown in the diagram above.
17. Run a length of 18/4 electrical cable (not provided) from the control box to the exterior junction box. Make connections inside the control box and junction box as indicated in the wiring diagram located at the back of this manual.
18. Bring 110/1/60 power to panel and wire according to the diagram located at the back of this manual.
19. Apply power to the control box and verify correct operation as follows:
  - a. One light must be on, both interior and exterior at all times.
  - b. With the restraint in the stored position, the exterior light will flash GREEN and the inside light will be solid RED.
20. If the lights do not operate as described above, there is a field wiring problem. Turn off the power and check the wiring per the Wiring Diagram at the back of this manual. Rewire as required.

21. Instruct the dock workers how to correctly use the TRUCK-LOCK. The Operating Procedure can be found in the next section.

## **Dock Leveler Interconnect**

There are two sets of "dry" contacts provided in the MTL-250 control panel for the purpose of interconnecting a powered dock leveler, air seal or other piece of dock equipment.

These contacts close when the inside light is green (TRUCK HITCHED) or alternately flashing red/green (RESTRAINT BYPASS).

The contacts are rated at 5A@250VAC (Resistive).

The contacts are to be used for control voltage and current levels only.

Refer to the wiring diagram at the end of this manual for the terminal number pair for the interconnect function.

## **Installation of Optional Driveway Mounting Plate**

When the optional driveway mounting plate is used, the driveway material must be concrete. For driveway materials other than concrete, a stepped concrete pad must be poured as shown next page. Allow concrete to properly cure before installing restraint.

Place plate on driveway or concrete pad.

Place bottom of TRUCK-LOCK on the driveway plate. Keep both the TRUCK-LOCK and driveway plate centered with the dockleveler pit.

Make sure the horizontal shear plate is welded to the restraint back plate as previously noted in Installation Instruction 4a and b.

Weld the bottom of the TRUCK-LOCK back plate to the driveway plate, as shown on next page. Paint welded areas to prevent rust.

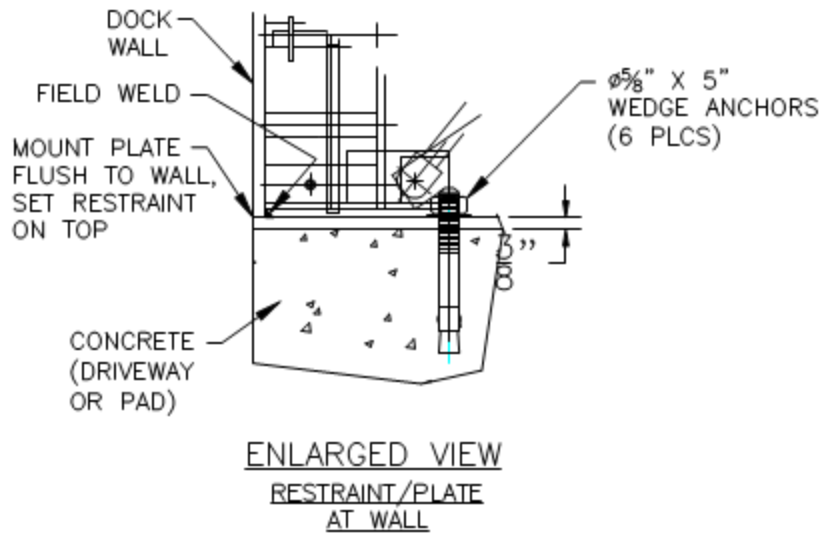
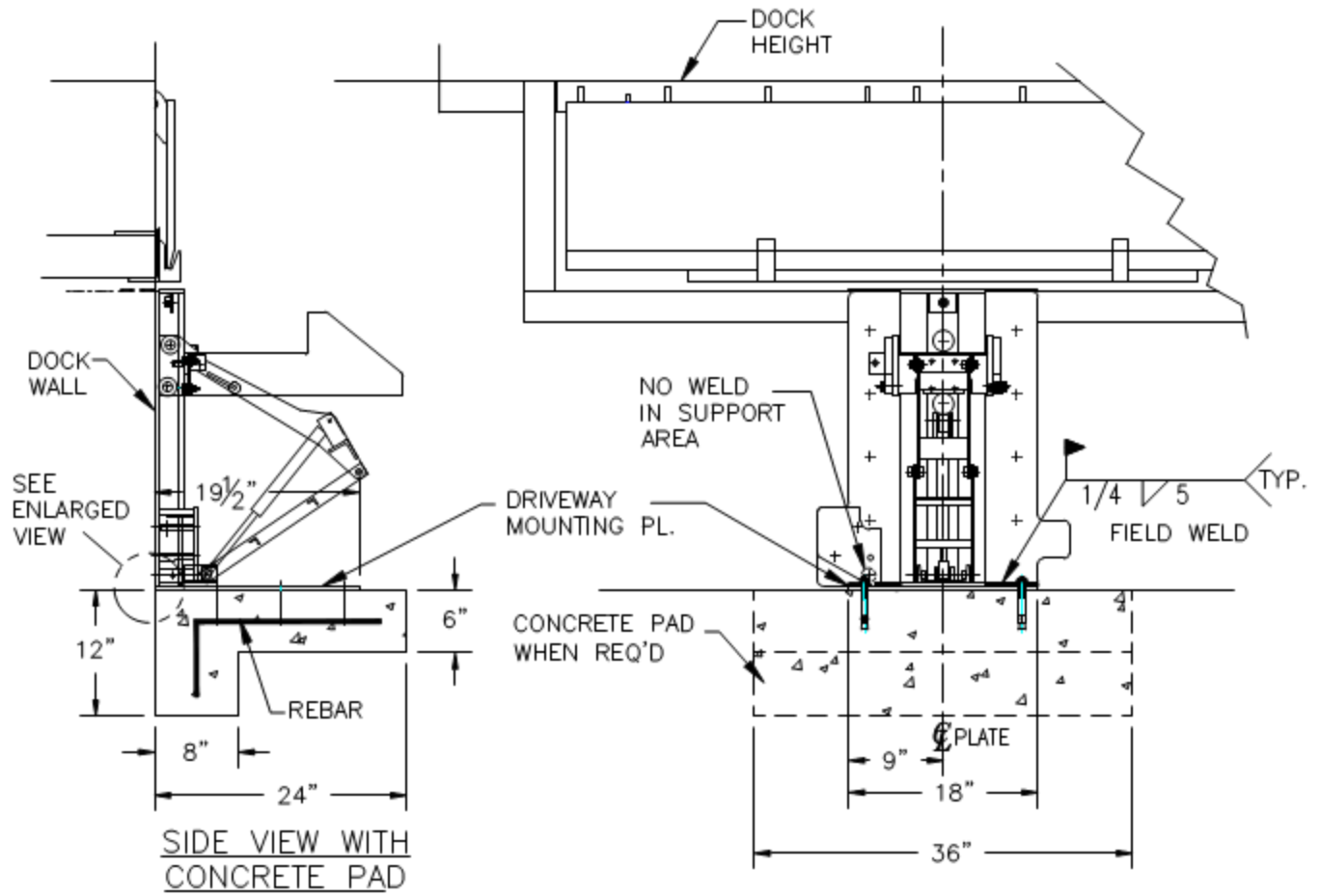



# Operation



## WARNING

Before operating or maintaining this truck restraint, read and follow the safety practices contained in this manual. Failure to follow the guidelines in this manual and those in effect in the workplace can result in serious bodily harm and equipment damage.

Do not load or unload any truck unless you make certain the TRUCK-LOCK has securely engaged the truck's ICC bar and that the truck brakes are set. If the TRUCK-LOCK does not engage the truck's ICC bar for whatever reason, THE TRUCK'S WHEELS MUST BE CHOCKED BEFORE LOADING OR UNLOADING CAN BEGIN.

Failure to store the TRUCK-LOCK when not in use could result in damage to the TRUCK-LOCK and incoming trucks.

### To Hitch Truck:

1. Position truck against dock bumpers and set brakes.
2. Using the pushbar provided with the TRUCK-LOCK, push the latch lever down. The hook will rise to engage the truck's ICC bar.
3. If the truck cannot be hitched, the inside red light will remain lit, and if equipped, the optional alarm will sound. Chock the trailer wheels and make certain that the brakes are set. Turn the "RESTRAINT BYPASS" switch to ON. The alarm will silence and the interior red and green lights will stay on.

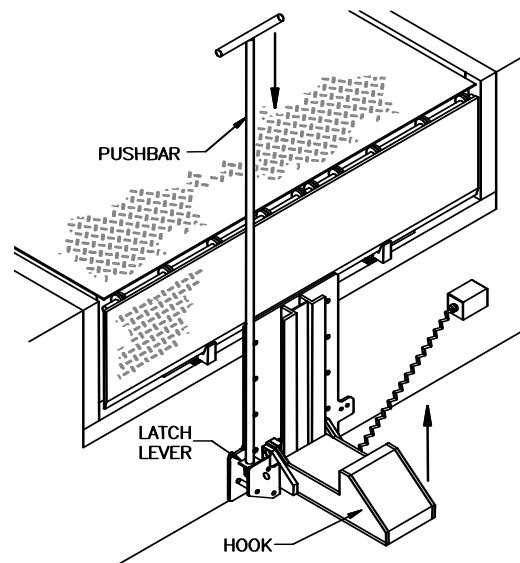

### To Release Truck:

1. Using pushbar, press the hook down until it latches. Push straight down in the centre at the rear of the hook as shown in the diagram.
2. Turn the "RESTRAINT BYPASS" switch to OFF.
3. The inside light will switch to a solid red and the exterior light will flash green.
4. The truck may now pull out.

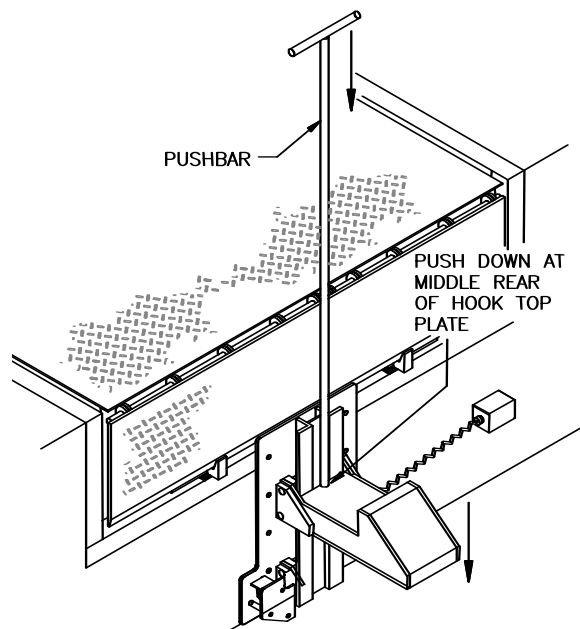

# Troubleshooting

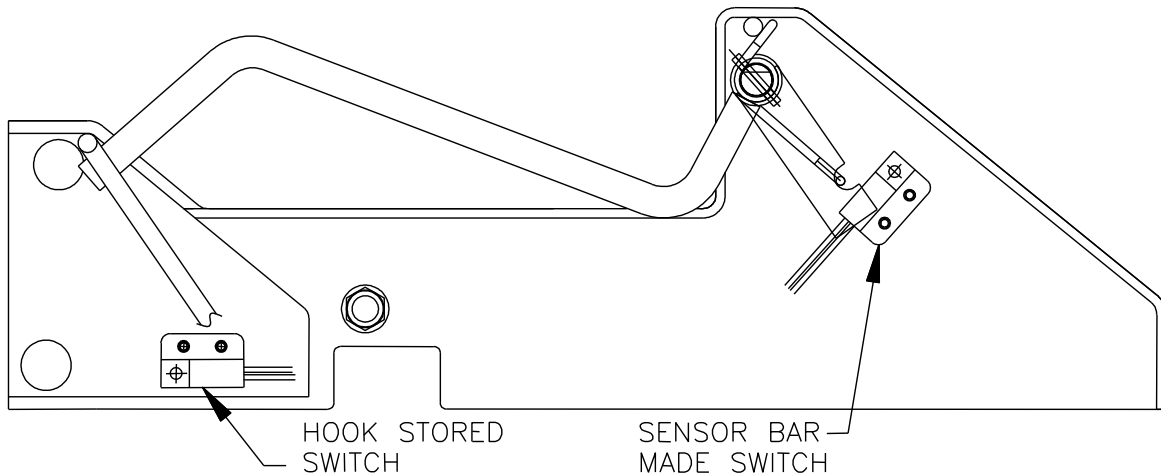

<b><u>PROBLEM</u></b>	<b><u>CAUSE</u></b>	<b><u>CORRECTIVE ACTION</u></b>
No interior or exterior signal lights.	1.No power to panel.	Check that power is coming into control panel.
	2 Control panel fuse blown.	Check Fuse and replace as necessary.
Outside light stays flashing red regardless of hook position.	Control panel not “seeing” change of state in hook stored switch.	<ol style="list-style-type: none"> <li>1. Check for missing or damaged stored switch.</li> <li>2. Check continuity of stored switch wiring to control panel.</li> <li>3. If wiring checks out OK, place a piece of steel against switch sensing face. If lights do not change, replace switch.</li> </ol>
Inside light stays flashing red and alarm sounds even when hook sensor bar is deflected.	Control panel not “seeing” change of state in sensor bar switch.	<ol style="list-style-type: none"> <li>1. Manually deflect sensor bar and verify that trigger plate passes within 1/4” of round sensing zone.</li> <li>2. Check for missing or damaged sensor bar made switch.</li> <li>3. Check continuity of sensor bar made switch wiring to control panel.</li> <li>4. If wiring checks out OK, place a piece of steel against switch sensing face. If lights do not change, replace switch.</li> </ol>

# Maintenance Schedule

**⚠ WARNING**

Before servicing this restraint, read and follow the safety practices contained in this manual. Failure to follow the guidelines in this manual and those in effect in the workplace can result in serious bodily harm and equipment damage.

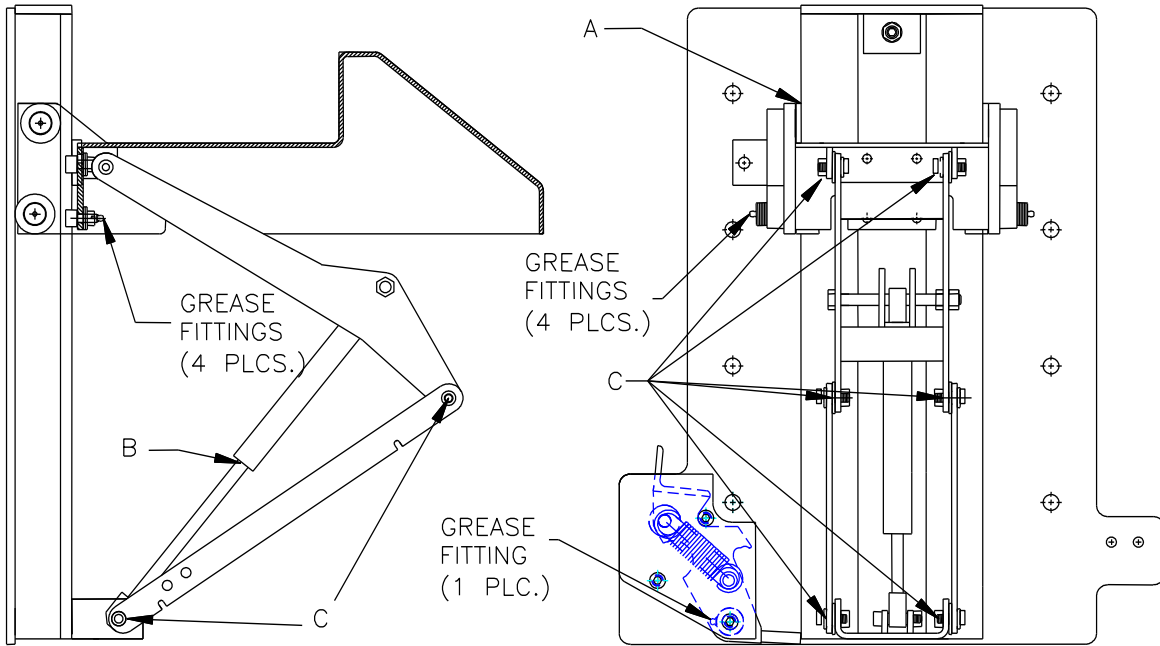

Item	Lubrication	Inspection	Cleaning
Grease Fittings (9 locations)	Every 90 days Using MP grease	None	Remove debris as required
- A - Track & Rollers	None required	Weekly – Check for bent track or damaged rollers	Remove debris as required
- B - Gas Spring	None required	Monthly – Check for oil leaks	Remove debris from rod as required
- C - Pivot Points (7 locations)	None required	Monthly – Check for loose fasteners- Tighten as required	Remove debris as required
Driveway Area Around Restraint	None required	None	As required to remove debris
Signal Lights Inside & Outside	None required	Daily check that all bulbs are working	Clean lenses as required
Concrete Anchors (11 locations)	None required	Weekly check that all anchors are tight. Re-tighten if necessary	None required

# Parts Replacement



## WARNING

*Before servicing this restraint, read and follow the safety practices contained in this manual. Failure to follow the guidelines in this manual and those in effect in the workplace can result in serious bodily harm and equipment damage.*

*Always replace traffic light bulbs with 28VDC, #2233 bulbs or equivalent. Using 12V automotive bulbs, such as a#1156, will cause damage to the control panel components that will not be covered under warranty.*

## NOTE

compressed when the restraint stop plate is installed. To avoid pinching fingers or other body parts, use caution when removing the stop plate.

The gas spring is partially

## Removing Hook From Track

If the hook has to be removed to replace damaged or worn parts, the following procedure must be used to avoid personal injury.

1. Store hook.
2. Unscrew retaining bolt from front of track and remove stop plate.
3. Apply weight to the hook and release the latch.
4. Allow the hook to raise slowly to the top of the track.
5. Block up the restraint hook to support its weight when the gas spring is removed.
6. Remove the upper cylinder bolt and jam nut.

## NOTE

come apart easily using only moderate hand pressure. Do not use a pry bar on the rod as it may damage the surface causing premature failure of the gas spring.

The gas spring should

7. Once the gas spring is removed, the hook can be lifted out of the track and lowered to the ground in front of the backplate without disconnecting any of the linkages.

## Re-installing Hook Into Track

1. Lower hook back into track and block up at a height so that the gas spring may be re-installed easily.
2. Position the cylinder end block between the mounting brackets and insert the 5 ½" long bolt from the left side of the arm assembly. Replace the jam nut on the inside of the right tension arm and nylock nut on the outside of the tension arm.
3. Apply weight to hook to lower it into the latched stored position.
4. Re-install stop plate and retaining bolt.

# Wiring Diagram

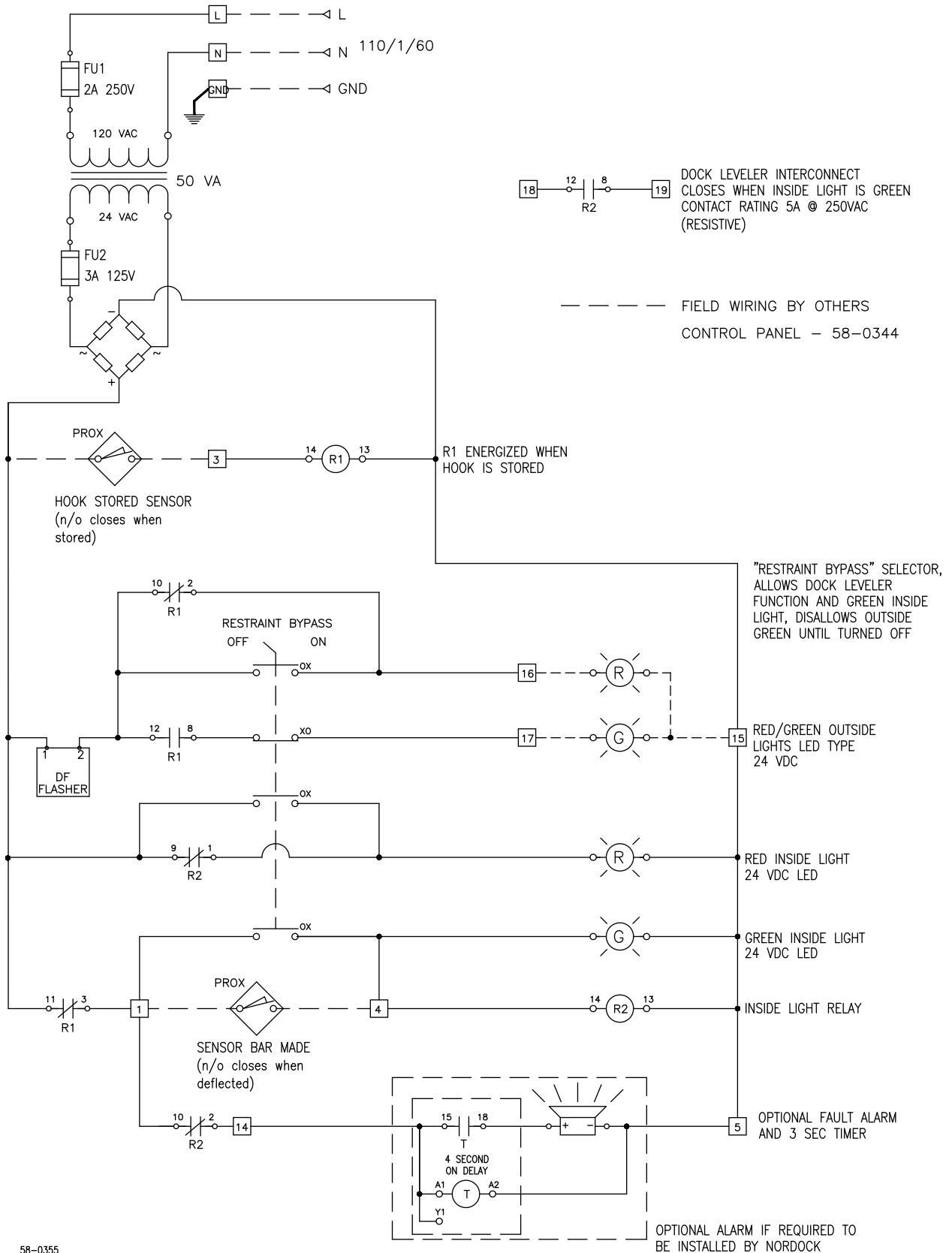

58-0355

# Parts List

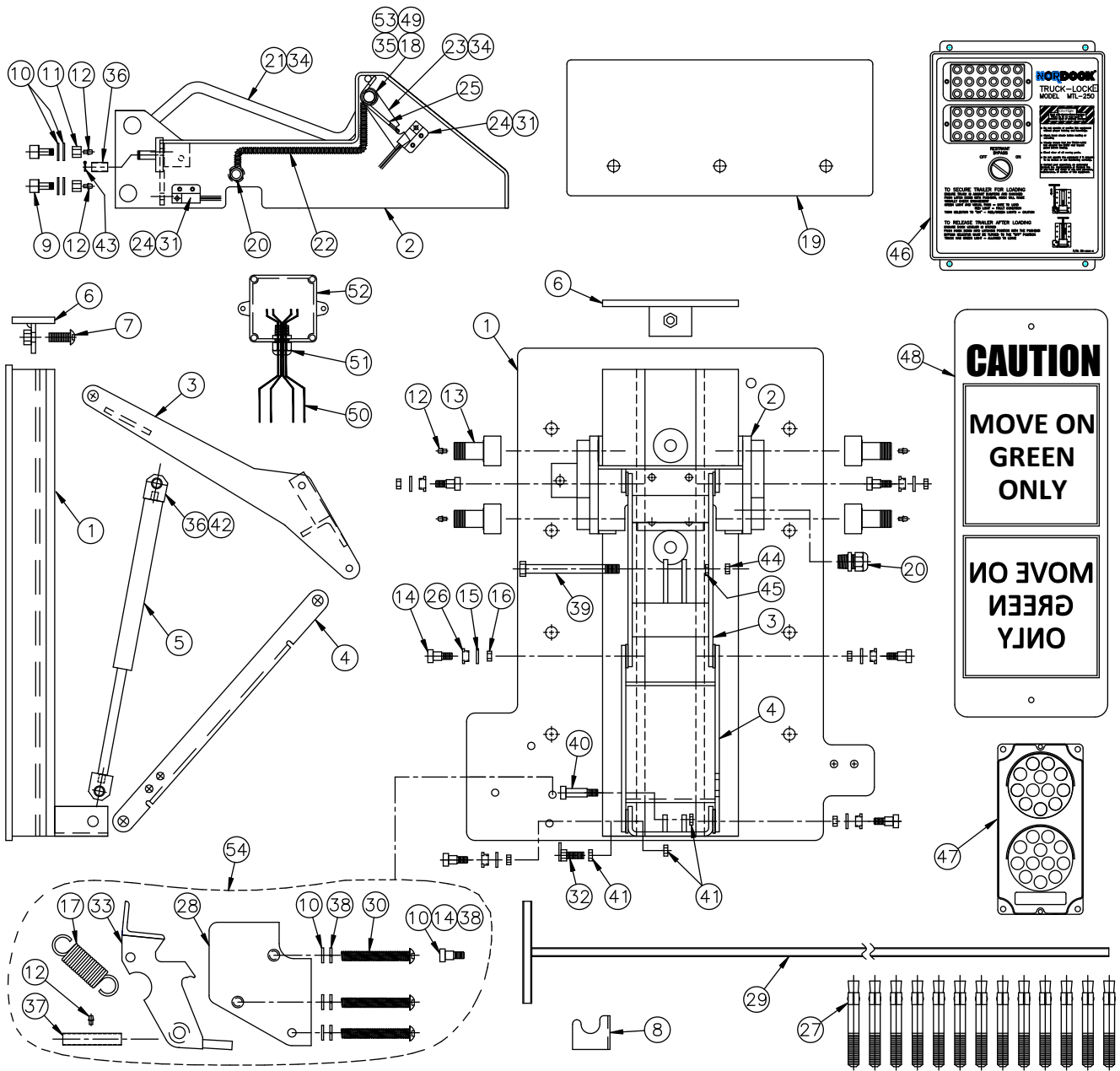

Item	Qty.	Description / Model	P/N	Note
1	1	Back Plate Weldment	52-0158	
2	1	Hook Weldment	52-0102	
3	1	Triangle Arm Weldment	52-0157	
4	1	Tension Arm	53-0123	
5	1	Gas Spring, MTL Series Restraint (Rod End Down)	Gas Spring only..... C/w end blocks (Pt 42) and Bushings (Pt 36).....	53-0164 52-0166
6	1	Stop Plate Weldment	52-0106	
7	1	Bolt, Button Head, 1/2" x 1 1/2" Stainless Steel	13-0966	
8	1	Push Bar Hanger Bracket	53-0110	

Item	Qty.	Description / Model	P/N	Note
9	4.	Bearing Cam Follower, Ø3/4"	13-0915	
10	12	Washer, 3/8" SAE, ZP	13-0203	
11	4	Nut, 3/8"-24 x1/2" Nylock, ZP	13-0969	
12	9	Grease Fitting, 3/16", Drive-in	13-0655	
13	4	Bearing, Cam Follower, Ø 1-3/4", Heavy Stud	13-0916	
14	7	Bolt, Shoulder, 1/2" x 1/2", ZP	13-0965	
15	6	Washer, Flat, 1/2", STD, ZP	13-0267	
16	6	Nut, Hex, Jam 3/8"-16, Nylock	13-1331	
17	1	Extension Spring, .148" Wire, 4-1/2" FL (Latch)	23-0441	
18	1	Pivot Shaft Sensor Tube	53-0183	
19	1	Horizontal Shear Plate, ZP	53-0108	
20	1	Connector, 1/2" Threaded, Strain Relief, Aluminium	13-1013	
21	1	Sensor Bar Weldment, TL Series Restraint	52-0111	
22	2	Conduit, Flex, 1/4" x 14" long	13-1159-14	
23	1	Sensor Bar Trip Plate, TL Series Restraint	52-0110	
24	2	Proximity Switch, N/O, 18" Wire Leads (P/C FP2000)	13-0985	
25	1	Torsion Sensor Bar Spring	23-0131	
26	6	Bushing, Flange, 1/2" ID x 5/8" OD x 3/8", Oilite	13-0953	
27	13	Anchor, Concrete, Wedge, Ø5/8" x 5", ZP	13-0779	
28	1	Latch Cover Plate	53-0181	
29	1	Push Bar Weldment	52-0108	
30	3	Bolt, SHCS 3/8 x 4 1/4, Plated	13-1482	
31	2	Spacer, Plastic, 0.210" Thick	(c/w 24)	
32	1	Bolt Weldment, 3/8, PRS Sensor	52-0119	
33	1	Latch Weldment	52-0107	
34	2	Socket Head Cap Screw, 1/4"-28 x 1/2" Long	13-1175	
35	3	Wire Ties 8"	S3-0078	
36	3	Bushing, Oilite, 1/2"ID x 5/8"OD x 3/4"Long	13-0963	
37	3	Pipe Spacer, 3/8" Schedule 80	53-0144	
38	4	Lock washer, 3/8", ZP	13-0767	
39	1	Hex Head Bolt, 1/2" x 5 1/2" long, plated	13-1638	
40	1	Shoulder Bolt, 1/2" x 1 1/4" long, 3/8" thread	13-1365	
41	3	Jam Nut, 3/8" plated	13-1021	
42	2	Cylinder End Block	C3-0118	
43	1	Cotter Pin, 1/8" x 1" long	13-0171	
44	1	Nut, Nylock 1/2"	13-0750	
45	1	Jam Nut, 1/2"	13-1639	
46	1	Control Panel, LED lights	58-0344	
47	1	Outside Traffic Light, Red and Green, LED lights	13-3282	
48	1	Sign, Outside Caution	23-0124	
49	1	Sensor Bar Pivot Shaft	53-0128	
50	1	Cable Sensor, TL Series Restraint	53-0118	
51	1	Connector, 1/2" Threaded, Strain Relief, Nylon	13-0419	
52	1	Enclosure, Conduit box, 4 x 4 PVC	13-2145	
53	2	Bushing, Flange, 5/8" ID x 3/4" OD x 5/8", Oilite	13-0433	
54	A/R	Latch Assembly complete (Pts 10,12,14,17,28,33,37,38)	52-0114	